

BROADCAST NEWS



PUTTING THE
TK-42 COLOR CAMERA
THROUGH ITS PACES
AT 1966
NAB CONVENTION



Vol. No. 129 JUNE 1966

"BIG TUBE" COLOR TV FILM SYSTEM

The 1½-inch vidicon in the luminance channel of RCA's color film camera provides a 50% larger image—50% larger than any used in other cameras. This gives improved signal-to-noise ratio, high resolution capability. Result: Unusually sharp reproduction of color films and slides.

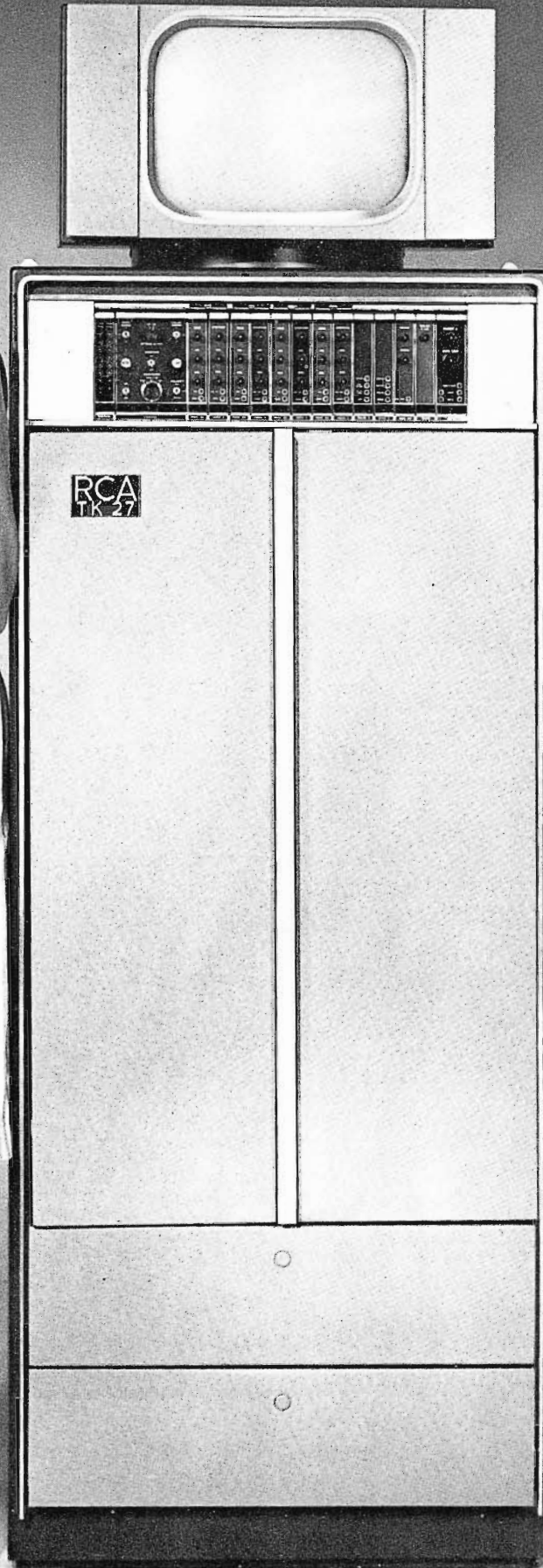

Vol. No. 129

June, 1966

BROADCAST NEWS

published by

RADIO CORPORATION OF AMERICA
BROADCAST & COMMUNICATIONS PRODUCTS DIVISION, CAMDEN, N. J.

issued bi-monthly

PRICE *in U.S.A. - - - - - \$6.00 for 6 issues*
outside U.S.A. - - - \$7.00 for 6 issues

C O N T E N T S

	Page
WLBW-TV Plans for the Big Look in Color Television	10
Two San Juan TV Stations Share Same Superturnstile Antenna	22
Putting the TK-42 Through its Paces at 1966 NAB Convention	27
Educational TV Stations and Conversion to Color TV	31
Color TV Tape Player, TR-3	44

Copyright 1966

All Rights Reserved Trademark(s) Registered. Marca(s) Registrada(s) Radio Corporation of America

PRINTED
IN
U.S.A.

COLOR TV DOMINATES BIGGEST, SELLINGEST NAB CONVENTION

In the afterglow of the biggest, noisiest, sellingest NAB convention ever, one central fact stands out. An industry moving swiftly to all color is demanding the highest quality in its broadcast equipment.

This was apparent as broadcasters swarmed into RCA's Matched Line exhibit, watched demonstrations, operated TK-42 color cameras for themselves and generally poked into every aspect of the equipment on display.

It was a compare-compare-buy show and, in spite of the delivery waits on some key items of color equipment, the broadcasters were leaving nothing to chance as they shopped. They wanted to outfit their broadcasting plants with the best color gear available.

At RCA's big (8,500 square feet) exhibit they watched the four-tube TK-42 go through a demonstration that simulated virtually every problem condition that might arise in the studio: severe underlighting and overlighting, silhouetting,



Robert W. Sarnoff, (left), RCA President, and Edwin C. Tracy, Division VP, Broadcast Equipment Sales, shown with TK-42 four-tube color camera which featured RCA's largest exhibit at NAB's annual show.

Model Diane Burkhardt rests on her mashie during break in golf routine before color cameras.



polarization, jewelry reflections and many more. The results bore out what they had heard about the TK-42's nonpareil performance.

Actually, the RCA exhibit contained not one but three color camera studios: one for the "torture" tests described above; a second where the visitor could take charge of a TK-42 himself, pan it, adjust the controls; a third studio set for taping. It produced pictures ranging from modishly-clad models to shimmering tropical fish in a glass tank of spectacular color.

The convention marked the first public showing of the TK-43, RCA's newest color camera, with an external zoom-type lens. The new camera uses the basic design of the TK-42 except for the lens system which in the TK-42 is built-in.

In the transmitter display, attention centered on the TTU-50C, a new 55-kw unit for UHF television service, which uses three identical 30-kw vapor-cooled klystrons. Two are for visual power and one for aural; all are of a type proven in commercial operation.

(Continued on Page 4)

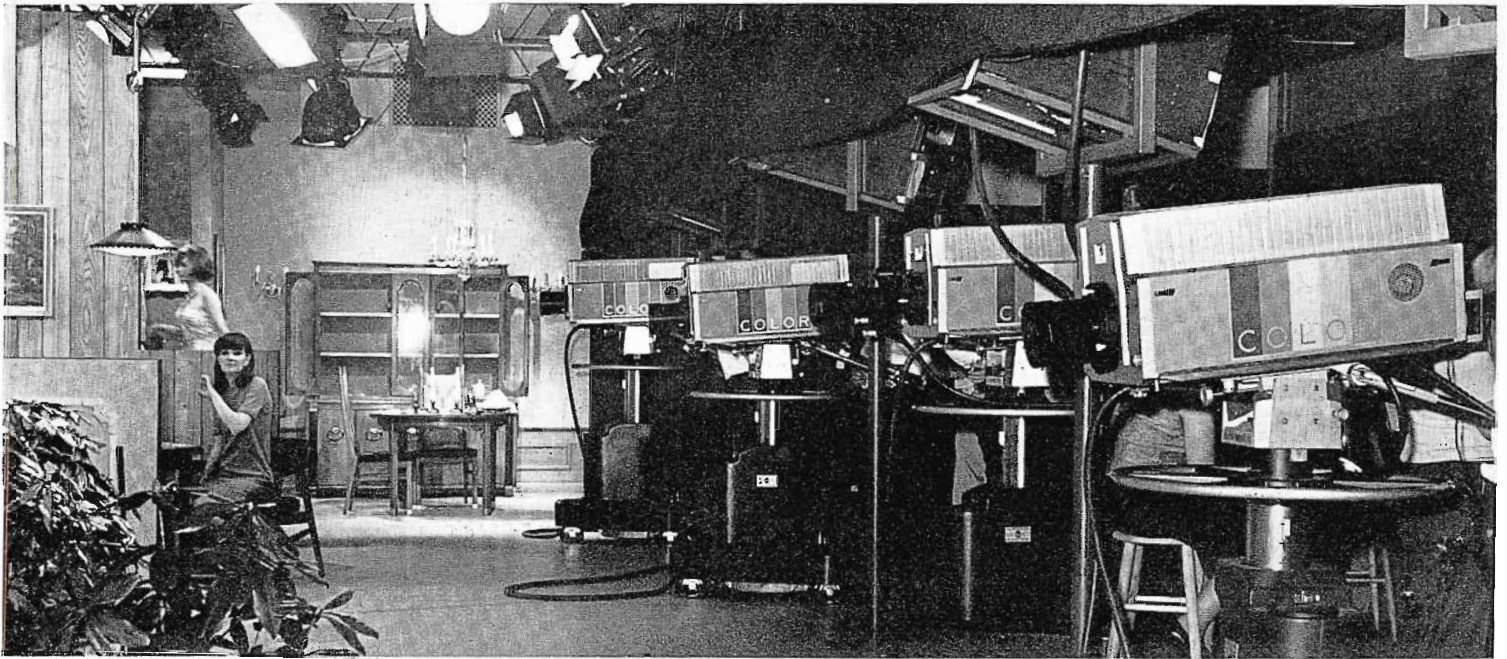

Battery of TK-42 cameras faithfully portrayed the color and activity in three adjoining studio settings, extending over 55 lineal feet.

Color Central provided video switching, effects and distribution, serving as intermediary between the TK-42s and 22 monitoring locations.



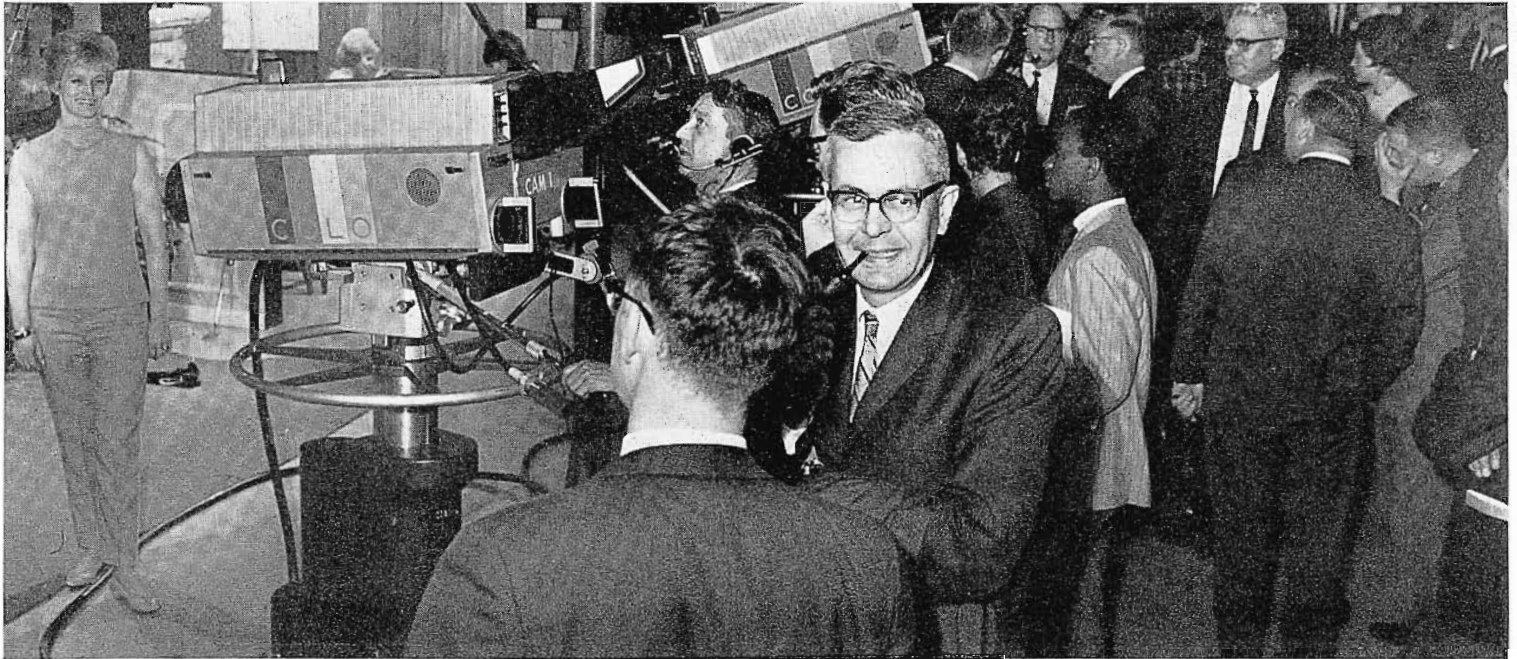

Girls, new equipment and crowds, the time-honored ingredients of NAB exhibits, left little time for pipe-smoking contemplation.

High-level color TV tape performance attained with high-band equipment was exemplified by the TR-70, shown for the first time.

COLOR TV DOMINATES

(Continued from Page 2)

Also shown for the first time were a new 25-kw VHF TV transmitter, new 1-kw AM and 40-kw FM radio transmitters, and an all-solid-state 6-kmc microwave system, TVM-6, for STL and intercity relay service.

Nearby in the TV tape area interest centered on the TR-70, RCA's latest entry for that medium and the first fully-integrated TV tape recording system for high-band color recording and playback.

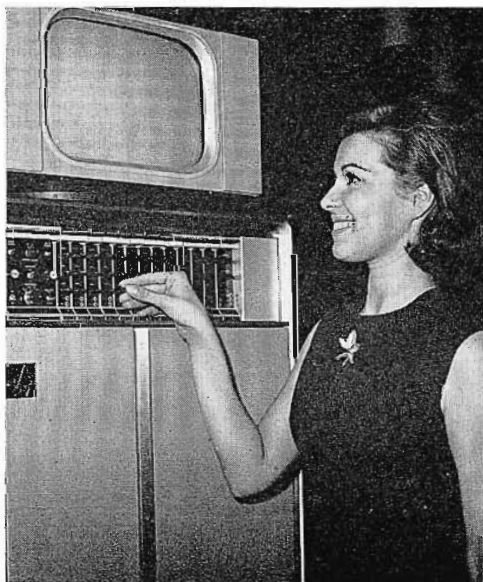

TK-27 demonstrations showed why it leads field.



The TVM-6 television relay system was in debut and Fran Harding helped celebrate by posing prettily with its dish and solid-state circuitry.



"Matched Line" equipments were previewed in miniature models by RCA's Peggy Hughes, here holding the TK-42.

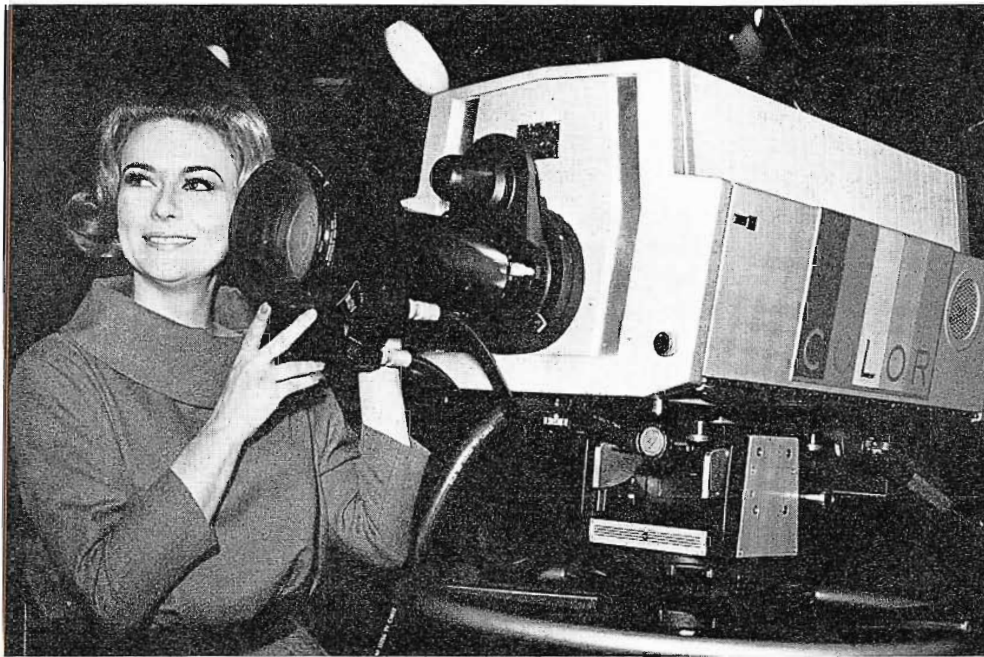

External zoom lens distinguishes the TK-43, newest four-tube color camera in RCA line.

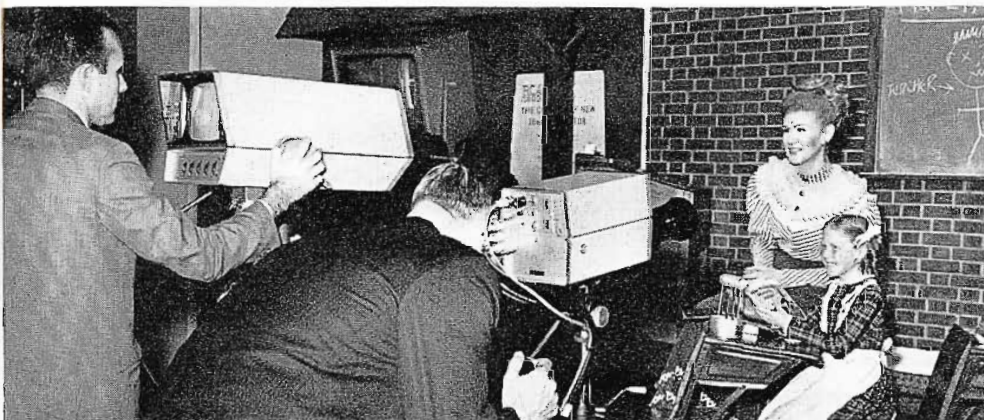

The TR-70, incorporating the latest "state of the art" advances, is designed, built and factory-tested as a complete system. It became evident to those watching the demonstrations that it was more versatile and easier to operate than any other high-band machine. Exclusive with the TR-70 is instant selection by switch of a choice of three recording standards; low-band monochrome, low-band color, or high-band monochrome/color.

Beyond the tape area, the broadcaster's keen eye could range over the most complete showing of station apparatus in TV industry history. He could see all of the RCA "Matched Line," so named because its separate items are matched in design, styling and performance to work together as a sophisticated system, the kind needed in a technically-demanding industry.

What the broadcaster saw was no new-paint-job project rushed out the door in time for the big show. Rather, he beheld the end-result of a multi-million-dollar investment, a massive effort that had involved some of the best brains in the broadcast equipment business. And having seen RCA exhibits before, he knew the promise of the exhibit floor lay in the solid performance the new equipment items would deliver in daily use, year after year.

PK-330 (left) and PK-301 cameras shoot schoolmarm, pupil models in schoolroom setting.

CANADIAN BROADCASTERS ORDER TK-42 CAMERAS FOR COLOR TV'S START NORTH OF THE BORDER

Canadian television broadcasters have ordered 23 type TK-42 four-tube color TV cameras in preparation for the start of experimental color broadcasts later this year. Sixteen cameras will be delivered to the Canadian Broadcasting Corporation and seven to CFTO-TV Toronto, one of Canada's largest privately-owned TV stations and the flagship station of CTV, the country's privately-operated network.

Beginning July 1, Canadian TV stations that have obtained government approval may broadcast color programs experimentally during the hours between normal sign-off and normal sign-on time. Daytime experimental broadcasts are allowed after October 1, and regular color programming begins January 1, 1967.

The CBC network purchase includes three mobile TV units to transport color cameras and associated equipment to program pickup points throughout Canada. Five of the new RCA cameras will be used in a broadcast studio CBC is erecting for the Canadian Universal and International Exhibition (Expo 67). The building will serve as one of the publicly-owned network's color studios after the Expo closes.

The cameras scheduled for delivery to CFTO-TV also will be suitable for mobile use in covering football, hockey and other public events. Earlier the station took delivery of two TK-41 three-tube cameras, the original type color camera, introduced by RCA, which helped to develop the current TV boom.

TK-27 CAMERA BRINGS FIRST COLOR TO CAIRO

The RCA International Division gave Egyptians a first look at color TV on their home grounds earlier this year with a demonstration in Cairo of the TK-27 four-tube color film system.

The occasion was the 1966 U.A.R. Industrial Exhibition where visitors could watch six RCA color receivers sparkle with the rich color and captivating excitement of Walt Disney cartoons. Appreciative

Egyptian viewers got the message as Donald Duck spoke in his universal tongue.

The TK-27, operating on NTSC standards, was officially shown to the engineering staff of the General Organization for Broadcast Engineering, Egyptian government officials and for delegates from various African nations attending the U. N. Territorial Conference that was being held in Cairo at the time.



RCA exhibit that gave Egyptians first look at color TV on their home grounds.

BURBANK PLANT GROWS TO MEET DEMANDS FOR NEW RCA TV EQUIPMENT



John K. West (left), RCA Staff VP, E. Robert Turner, Burbank City Manager, and Gordon W. Bricker, West Coast Operations Mgr., RCA, check building progress.

A building addition to the RCA Broadcast and Communications Products Division's plant in Burbank, Calif., has enlarged that facility's work area by approximately 8,000 square feet, an increase of some 25 per cent. The recently-completed construction was made necessary by demands for RCA's "Professional Television" equipment line, designed primarily for closed circuit systems use. Introduced early in 1965, the line has gained wide acceptance in government, industry and other markets.

Heading the line are PK-330 viewfinder and the PK-301 non-viewfinder cameras which provide many broadcast-type features for users who want high-grade performance at modest cost. The line also includes monitors, switchers and other items for full "turnkey" installations.

The Burbank plant also is the engineering and production center for RCA television film recorders and sound-on-film recorders used in the motion picture industry. The employees and activities now housed in Burbank moved there from Hollywood late in 1962.

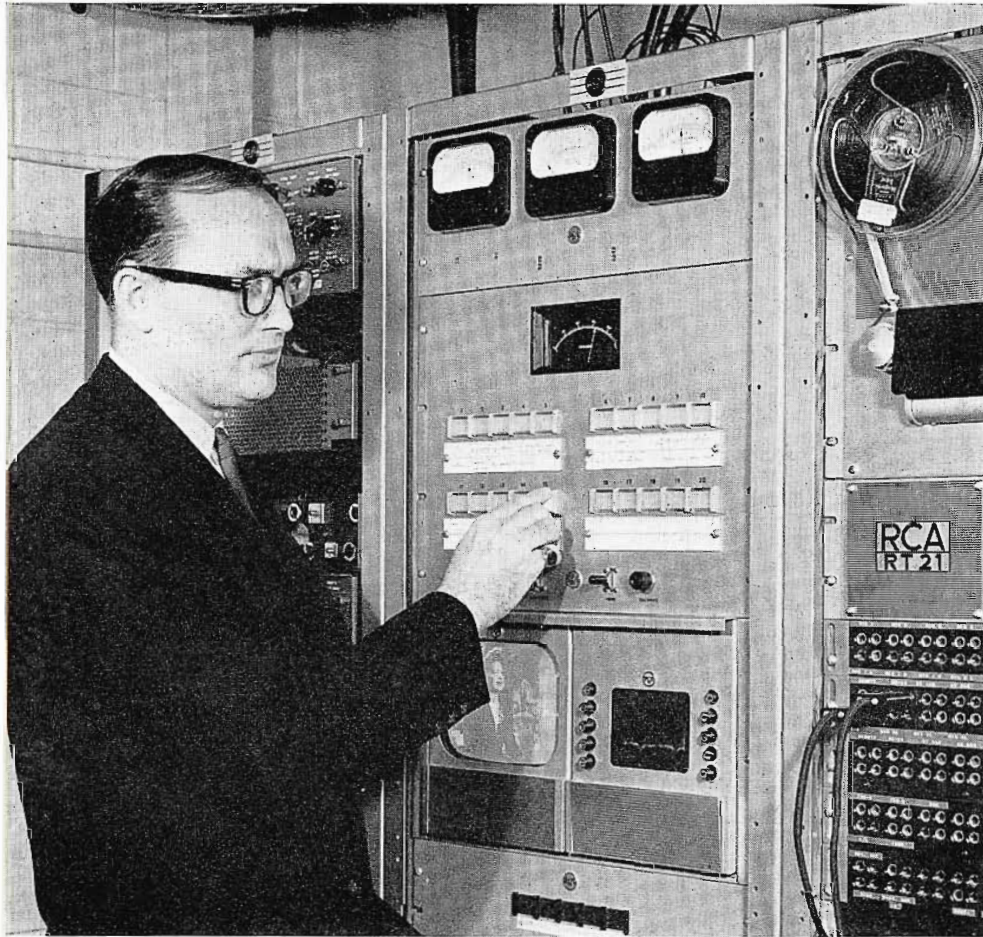

Gene Hill, Kaiser Broadcasting's Engineering Director, operates remote control unit at WKBS studios.

WKBS BECOMES FIRST STATION TO OPERATE RCA TV TRANSMITTER FROM DISTANT POINT

WKBS, Kaiser Broadcasting's new outlet for the Burlington, N.J.-Philadelphia, Pa., area, has become the nation's first television station to operate an RCA UHF television transmitter from a distant location. The control equipment is located in studios approximately 10 miles from an antenna farm in the Roxborough section of Philadelphia, where transmitters of WKBS and other TV stations are based.

While other broadcasters have remotely controlled RCA UHF transmitters from within the same building, the WKBS installation marks the first such control from a distant point. All new RCA VHF and UHF television transmitters have a built-in provision for remote control in anticipation of FCC approval of such operation. The FCC approved remote control of UHF transmitters, effective May 6, 1963, and is considering similar action on VHF.

The unattended transmitter operation

made possible by remote control enables the engineer, who normally would be stationed at the transmitter site, to work in the studio equipment area where he is available for other duties. Eugene R. Hill, Director of Engineering for Kaiser, said more efficient use of station technical personnel was the main advantage of remote operation. Another is the flexibility it provides in choosing separate and optimum locations for studio and transmitter.

WKBS thus could locate its studios at a point readily accessible to talent, client and staff personnel while the broadcasting site could be the antenna farm toward which receiving antennas already were oriented.

Control of the transmitter is accomplished through a console or rack-mounted system which includes audio and video gain and monitoring circuits, picture waveform monitors, and the lights, switches and meters needed for normal operation.

GEORGIA ETV NET MOBILE UNIT MOUNTS TR-4 FOR TV TAPE PREVIEWS

The Georgia Educational Television network uses an RCA TR-4 television tape recorder as the key element in its remote preview unit, used exclusively to screen TV tapes away from the production center.

The tape machine travels in the van with four 24-inch monitors which can be removed and positioned for viewing. GET

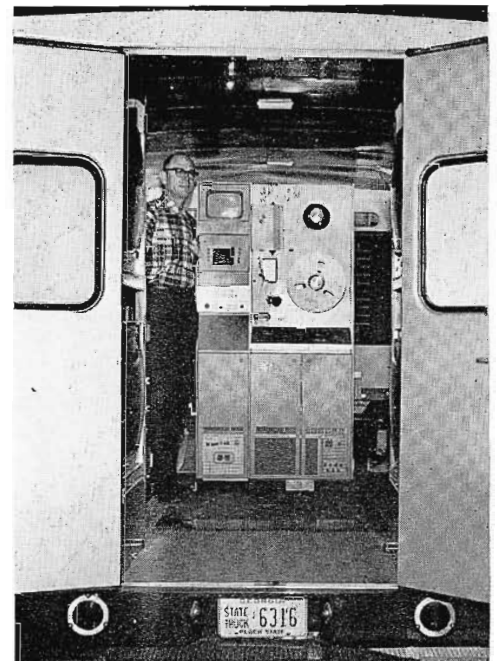

Georgia ETV's Thomas Dixon and tape machine.

executive Director Lee Franks says the mobile unit has been in use since the first of the year and has proved practical for viewings in school libraries, auditoriums and classrooms.

Successful operation of the unit has created a demand for TV tape showings and a second mobile unit is on order, according to Mr. Franks. The unit was designed by Harvey Aderhold, Director of Engineering for the Georgia ETV network, and Chester Halderman, Engineering Supervisor.

The TR-4 is one of three types of compact TV tape equipments in RCA's line and is frequently used in mobile units where the call is for broadcast-quality pictures. Other types are the TR-3 tape player and the TR-5 transportable recorder.

SUMMIT MEETING IN MEXICO JOINS MEN, TV TRANSMITTERS

Cerro de la Silla (Saddle Mountain) rises abruptly 3,500 feet at the edge of Monterrey, Mexico, and climbers gaining its summit are treated to a stomach-clutching view rarely equalled. It was there that XET-TV, Monterrey, chose to install a provisional transmitting facility, resulting in these spectacular photographs.

No roads reach the mountain top, and all equipment and supplies for the two-man engineering crew that mans the broadcast aerie for a week at a stretch are transported by helicopter.

Since these pictures were made, the equipment shown has been replaced by the station's TT-6AL transmitter and panel antenna which were removed from their downtown locations, lifted to the mountain and installed permanently. The temporary transmitter (TT-2BLN) had gone aloft as a single 3,600-pound load, was set up in the open air and covered with a canvas after sign-off each night.

And on these spring evenings, as Monterrey viewers tune their sets to Channel 6, a sharp picture appears and there seems to be more zing in the mariachi music as it radiates from high up on Cerro de la Silla.

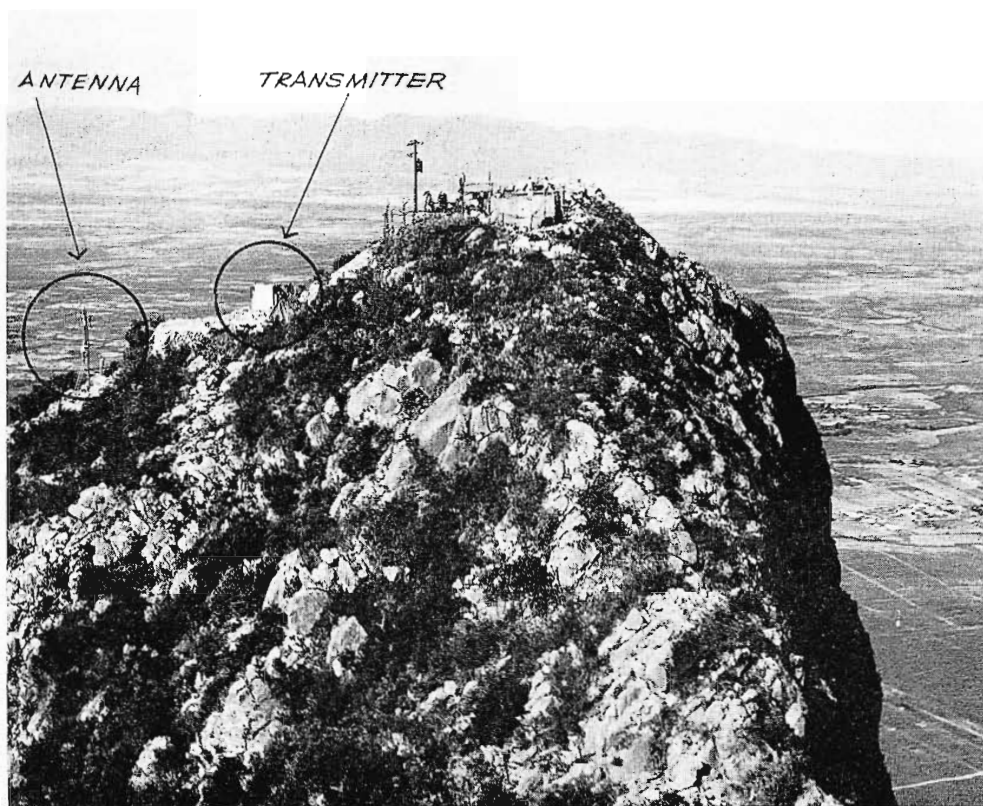

Leaving her in Monterrey in old Mexico? Watch that first step, it's a 3500-footer!



Transmitter swings from cable as copter nears broadcasting aerie.



Work crew sorts pay loads of several flights as assembly job begins.

**LARGEST 2500-MC EDUCATIONAL TV SYSTEM
IS DEDICATED BY NEW YORK ARCHDIOCESE**

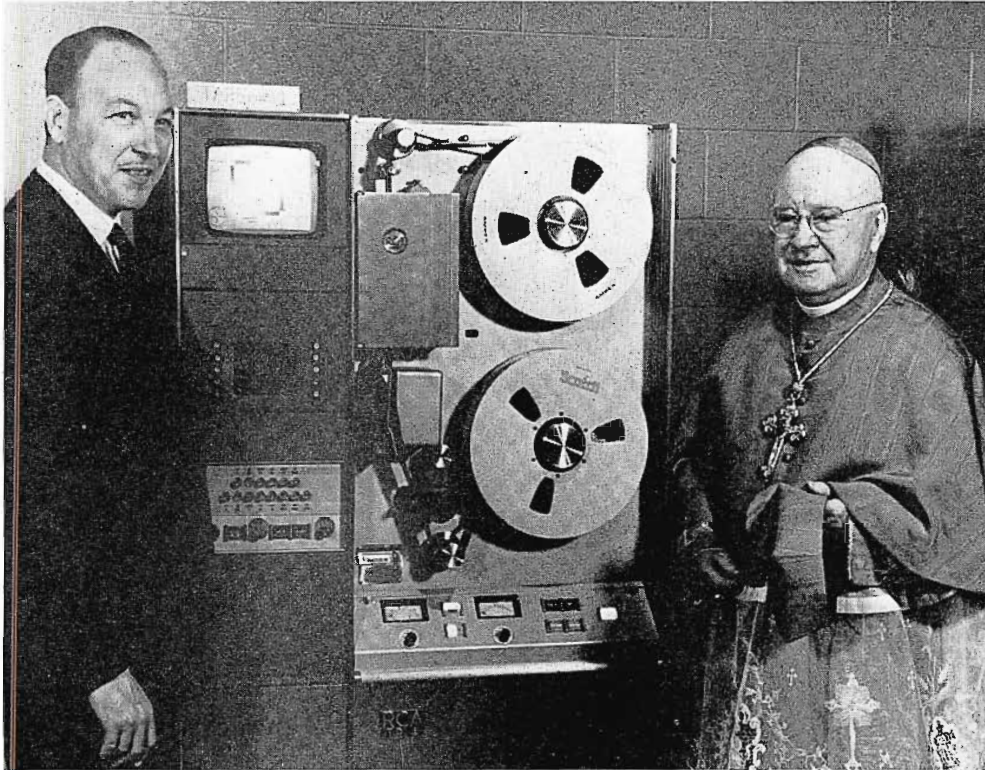

Robert W. Sarnoff, RCA President, and His Eminence, Francis Cardinal Spellman, shown with one of new TR-4 TV tape recorders at dedication ceremonies of Archdiocese of New York's ETV studios.



Father F. J. Sullivan checks microwave receiving dish atop Cardinal Spellman High School in Bronx.

One of the nation's largest educational TV systems, designed and built by RCA for the Catholic Archdiocese of New York, was dedicated May 17 by Francis Cardinal Spellman. When fully operational in September, the 2500-megacycle system will provide up to three simultaneous

programs for some 225,000 pupils in 400 elementary and high schools in the Archdiocese.

Speaking at dedication ceremonies in the new Yonkers, N. Y. studio building, Robert W. Sarnoff, RCA President, described the system as one of the out-

standing educational TV installations in the nation and said it should provide a new teaching tool of great versatility.

Major equipment items include TK-60 "live" cameras, TK-26 color and TK-22 monochrome film systems, and TR-3 and TR-4 TV tape machines.

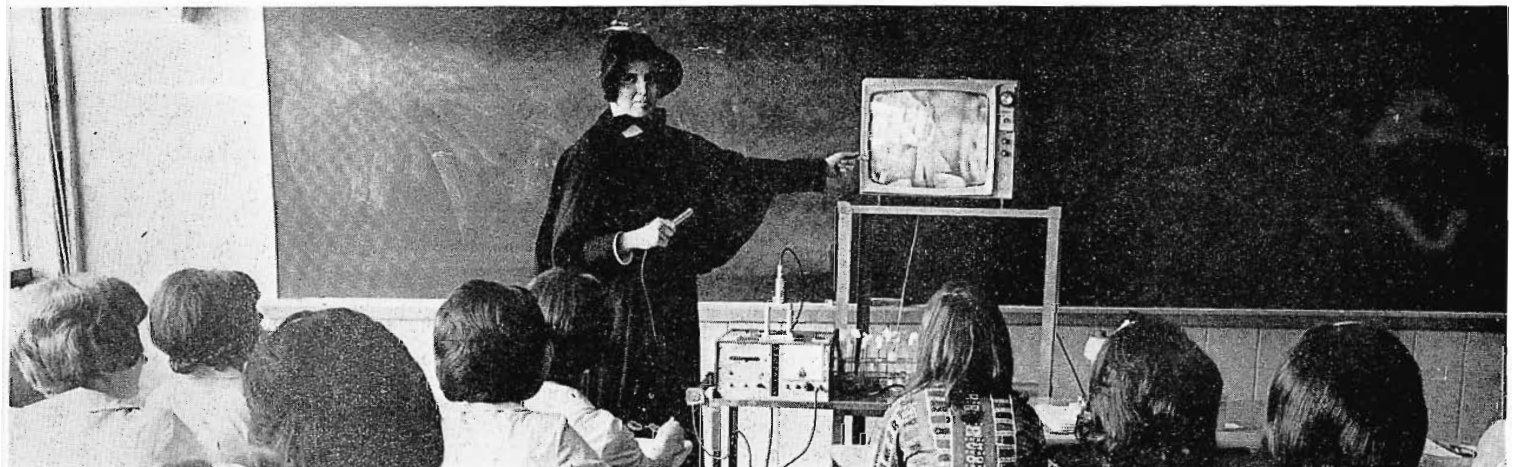

High school chemistry, taught here by Sister Marion Marguerite, is one of courses where TV will supplement classroom instruction.



FIG. 1. Building site on Biscayne Boulevard for ultra-modern WLBW-TV Studios.

WLBW-TV PLANS FOR THE BIG LOOK IN COLOR TELEVISION

Determined to be in the forefront of Florida's fabulous big sell, Mr. Charles H. Topmiller, president, and Mr. Thomas A. Welstead, vice president and general manager of L. B. Wilson, Inc., owner of WLBW-TV, are planning big for Channel 10, Television City in the nation's 17th market—Miami, Florida.

State promoters are pushing the blue skies and balmy climate as the ideal location for major studios, film producers, and TV networks. They have found Florida's sun-filled days and smog-free air the answer to a color cameraman's prayer.

As a result in Miami this summer, there will rise a full-color \$2 million television facility, incorporating a video tape center of the South, indoor and outdoor studios

film shooting and processing — all housed in a beautiful new three level structure, of pre-cast stone and glass, situated on busy Biscayne Boulevard.

Dedication and Schedule

Ground breaking ceremonies for the new home of WLBW-TV took place November 10, 1965. Florida's two senators, the mayor of Miami, and top station executives participated. Some 150 guests, including station personnel and their families watched the ten minute ceremony, then enjoyed refreshments. The entire proceedings took place in a festive tent pitched over the recently cleared site and were recorded on video tape and film.

Original planning dates back to inception of the idea for a new and permanent

home several years ago. However, because the station had to make a short on-air commitment, the present limited quarters were chosen. Actually, the real beginning dates from June 1964 when plans were made for the team trip, and architects were consulted. Traffic flow analyses and space requirement studies occupied another six months. By June of 1965 plans were in progress. In September, contracts were signed for procurement of the basic color TV equipments — film, tape, and live. Land had been procured and in November clearing operations and construction began. It is expected that the move to Television City will be completed in early Fall of 1966, so that full color operation will then be in effect.

FIG. 2. Mr. Charles H. Topmiller conducts WLBW-TV ground breaking ceremonies. Seated is Miami Mayor Chuck Hall.



FIG. 3. L. B. Wilson executives with Mayor Hall, congressmen and clergyman, operate five-handle shovel.



FIG. 4. One of two TK-27 color film chains complementing WLBW-TV's new RCA matched Color TV equipment.



FIG. 5. William M. Latham, chief engineer of L. B. Wilson, Inc., uses scaled cutouts to plan TV equipment layout.

N. E. 39th STREET

SITE PLAN
SCALE 1/8"=1'-0"

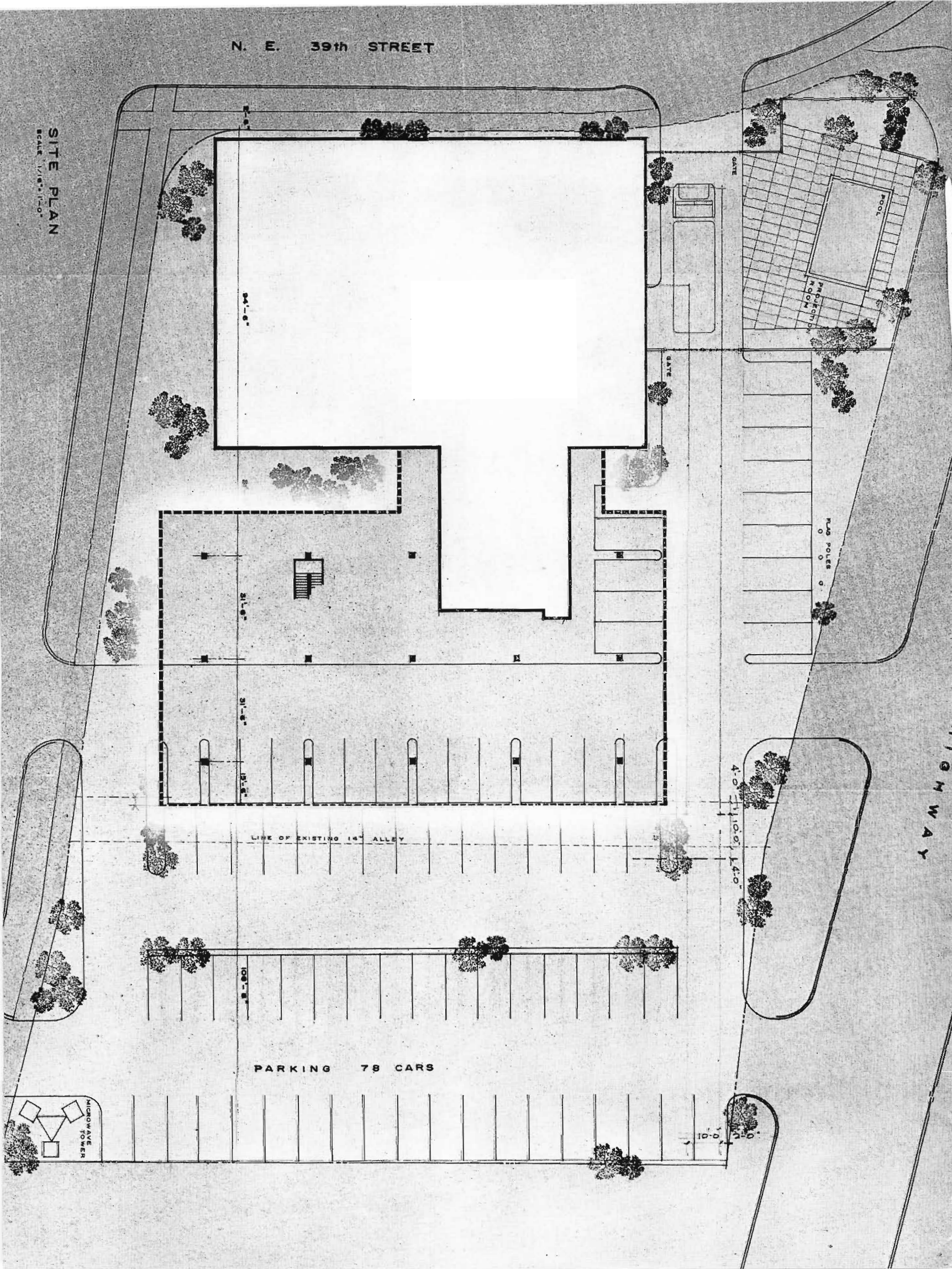

94'-0"

21'-0"

21'-0"

18'-0"

LINE OF EXISTING 14' ALLEY

PARKING 78 CARS

MICROWAVE
TOWER

HIGHWAY

GATE

GATE

LINE POLES

POOL

PRODUCTION
ROOM

10'-0"

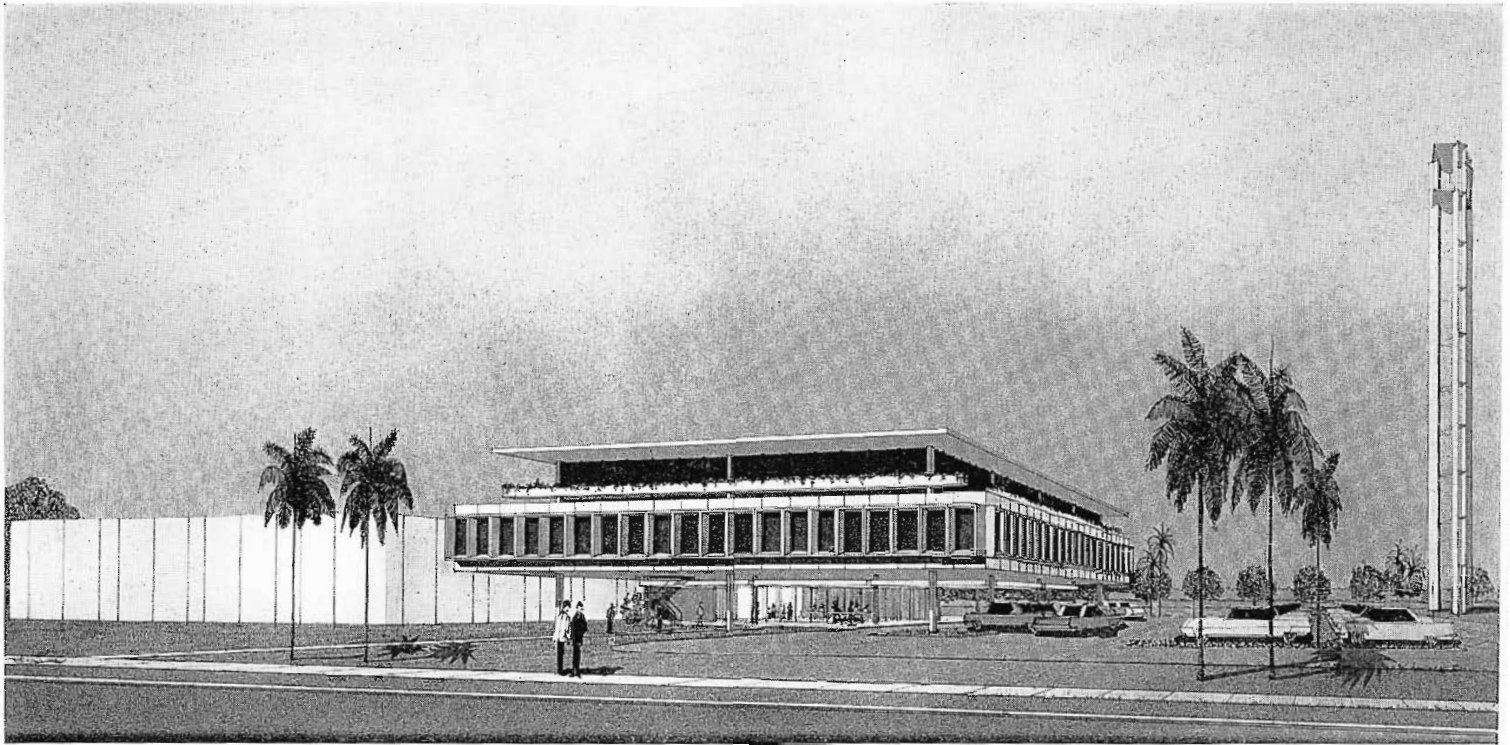

FIG. 7. Artists' sketch depicts modern studio building for WLBW-TV. Studios are housed in two-story facility at left. Three story part of structure contains equipment rooms, engineering, sales and executive offices. Almost two acre site includes spacious parking area and suburban landscape grandeur. Structure at right is 125 foot microwave tower visible for miles.

Planning Television City

The WLBW-TV planning story has three main divisions: Design, Location, and Layout of the New Building; Parameters for Programming and Commercial Production; and Engineering Considerations for Efficient Operation.

Supplemented by training programs for employees and clinics for advertisers and agencies, the framework for a very successful color TV operation has been laid.

Travel Itinerary

One of the first steps in determining design factors was to form a team for investigating what the industry is doing in the planning of updated television facilities. This was composed of: Chas. H. Topmiller, president; Thomas Welstead, vice-president; and Wm. M. Latham, chief engineer (of L. B. Wilson, Inc.).

The team visited following modern television stations and network facilities:

WAVE, Louisville, Ky.

WFIL, Phila., Pa.

KHOU, Houston, Texas

WKRC, Cincinnati, Ohio

ABC, New York City

KTRK, Houston, Texas

and the RCA World's Fair Color TV Studios in New York.

The Big Question

The basic building design question became: Shall it be circular or rectangular? This problem had to be resolved before acquiring land. In fact, the size of the site required for circular construction tended to sway the decision the other way. Fact of the matter is: If a circular station building is not larger than 200 feet in diameter, it begins to look like a silo! On the other hand, if larger than 200 feet, it must be rather high in order to avoid the unattractive appearance of a mushroom pod.

One of the circular buildings visited very neatly straddled between these para-

meters of enormous size by building on a hillside. In this case, the contoured hillside adds a graceful appearance, since one may go in on the third level on one side and the first level on the other. Groupings of trees also complement the exterior, producing landscaped grandeur. However, this near-ideal condition was not to be found in Miami.

Further, upon close examination, the circular building is not basically circular in construction but is made up of a number of wedge-shaped sections, so that in the final analysis, the interior layout is not materially altered for better or worse. Actually, a rectangular building is easier to lay out and less wasteful of space.

These facts forged the design decision favorable to the traditional rectangular shape.

Building Location

The problem was to acquire an almost two-acre site near the expressways, preferably in the downtown area. A choice location was uncovered along U.S. 1, main artery of Miami, in center of the business

FIG. 6. Architects plan view of 36,000 square foot precast stone and glass structure.



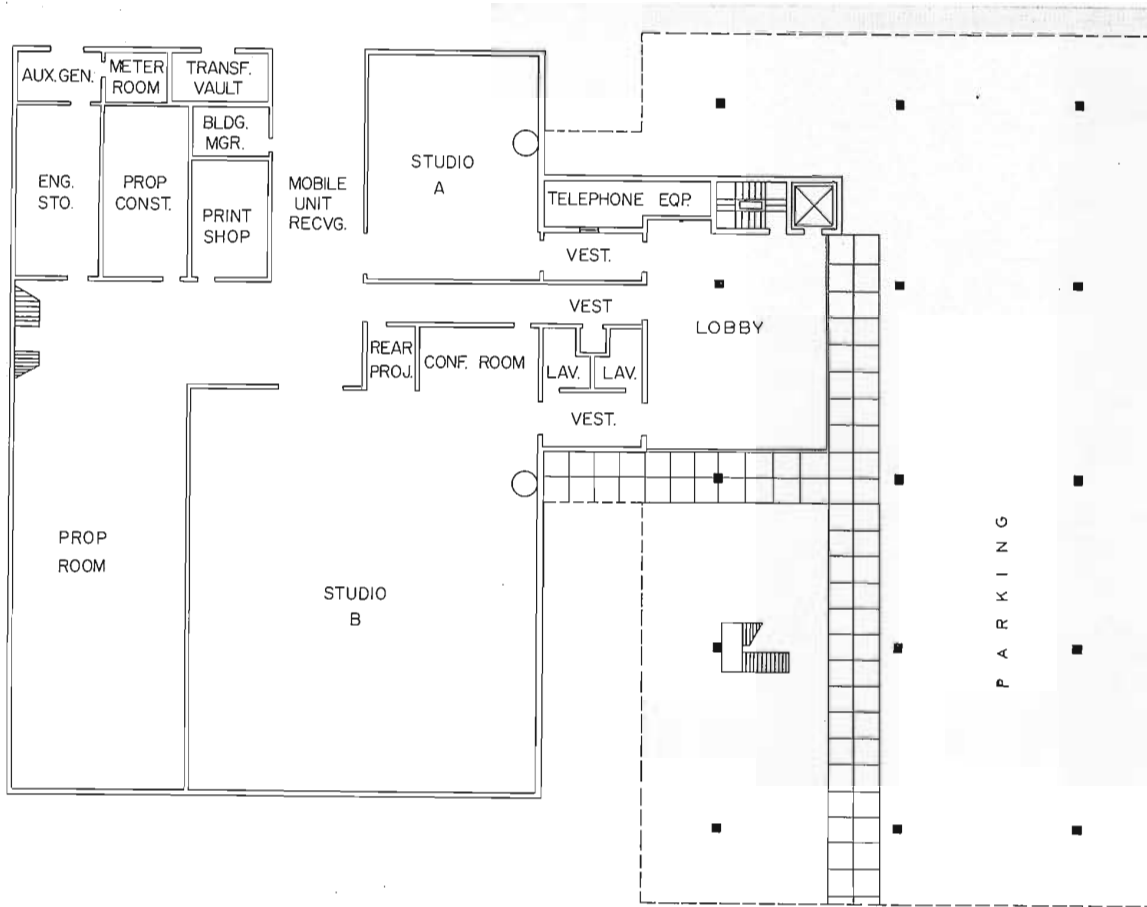

▲ FIG. 8. FIRST FLOOR PLAN.

▼ FIG. 9. SECOND FLOOR PLAN.

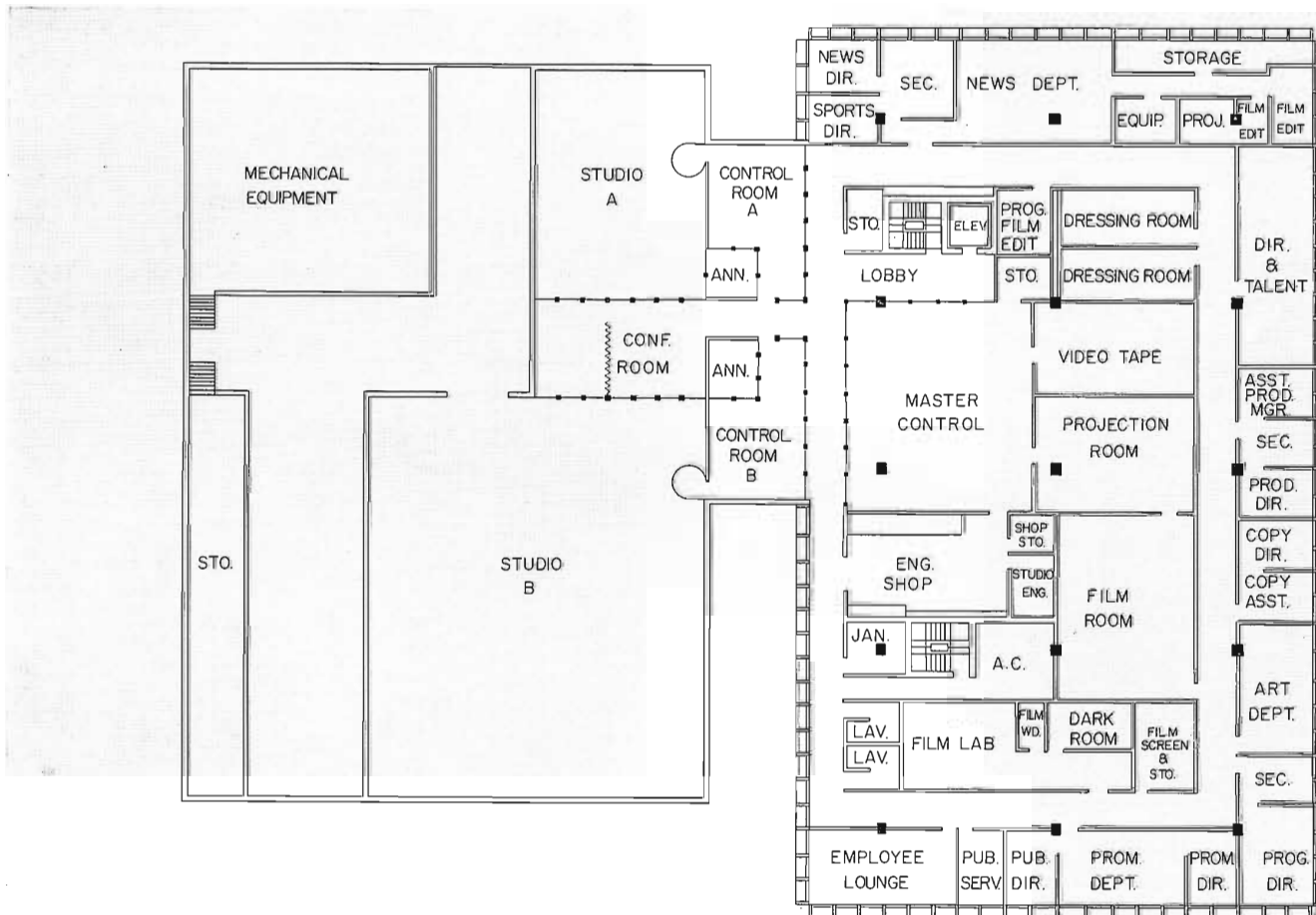

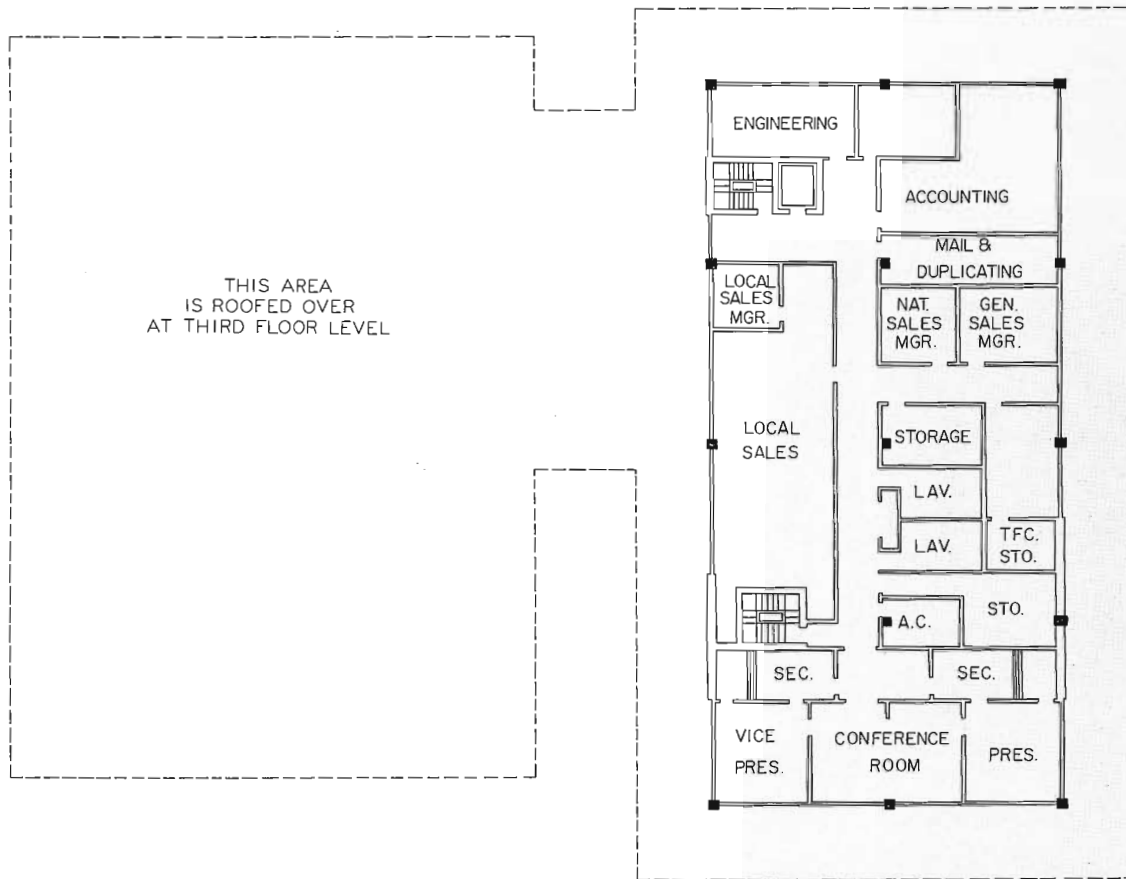

FIG. 10. THIRD FLOOR PLAN.

area. Since it also provides nearby access to east-west expressways, this was determined to be the best location.

Making the Building Layout

The first need was for more space. The new building provides 40,000 square feet of usable floor area. In order to apportion this new space properly and lay it out for maximum utility, an analysis was made by means of a traffic flow chart. This plotted who goes where (to what office) — and revealed the various contacts made by employees. Out of this analysis came the layout.

The result of the traffic flow analysis placed operations on the second floor, studios and reception on the first floor, and administrative offices on the third level. The net result is a well-designed building arrangement — people who should be together are together.

In a way, the design could be termed an exercise in cooperation. Operating in cramped quarters, department heads and administrators were requested to sketch areas needed for their operations and to suggest furnishings and facilities. Ideas and comments were received and digested and then incorporated into the finished design.

For example, the TR-22 Tape Recorder used for editing will be removed from the main VTR room to a special tape edit room in the new building as a result of the production department's suggestion for a separate room for a specific job requiring isolation.

The general philosophy of the layout has been to have each portion of the building a separate entity — avoiding the trap of becoming one big conglomerate mess — but all can be tied into a unified operating TV center.

Since the station is a gathering point for material from Haiti, Central and South America, to feed the ABC network, it is important to be able to isolate this function — separate and distinct from local production — when necessary. For example, under the proposed arrangement, an ABC news crew from Latin America may use the film department's facilities to process and to edit without bogging down the WLBW-TV local operation.

Measuring the Decibels

Typical of the care taken by the engineering department to assure proper operating atmosphere in the new building, sound-level measurements were made over

a period of a week at the site. As a result, the wall thickness was increased. Additional mass was required to counteract the low-frequency rumble of nearby buses!

Description of New Facilities

The entire first floor of the spacious new building is devoted to a reception area, a studio viewing area, and the studios. These two color studios will be large enough to accommodate network program originations and will be equipped with five RCA TK-42 live color cameras. There will be a large parking area for accommodating 78 cars. Outdoor facilities include a swimming pool for televising programs and commercials.

Pulse of the television operation is located on the second floor. Here are located the production, engineering, news and promotion departments. Also all control rooms, film processing labs and engineering equipment centers.

The third level houses the administrative center of the station. Sales and executive offices are all located on the third floor.

Alongside the building, a 100-ft. microwave tower will beam the programs to the transmitter (at N. Dade Co., some ten

miles away), make network connections, and receive remotes. Two rooms at the top, house weather radar and STL equipment. Streamlined by huge vertical slabs of concrete, the tower will rise like a huge monolithic pillar to become the image of the station — seen for miles around.

The building was designed by the architectural firm of Herbert H. Johnson Associates, Miami. Studio plans, equipment, and facilities are the work of station executives, chief engineer, and department heads.

Programming for Color

The new building is being planned for full color operation. Both studios are being equipped for originating all local live programming in color — from early morning kiddie shows to the late evening news and weather. Complete color processing equipment will be installed to enable the station to process all its local color film and slides. Present color TV film and video tape systems will be expanded. This will make the station one of the finest full-color facilities in Florida.

The current program schedule of

WLBW-TV provides eight hours per week of local color film attractions. This is in addition to the ABC-TV network color schedule. In addition, certain syndicated video tape programs are being presented in color.

"Matched" Color TV Equipment

Since the new building is being built from the ground up for color, the entire complement of equipment is likewise all tint. The most modern RCA "New Look" designs have been chosen. Already installed is a color film system, consisting of TK-27 Color Film Camera, TP-15 Multiplexer, two TP-66 TV Film Projectors, and a TP-7 Slide Projector. In the new building, a similar color film system will be added. Proposed studio equipment includes five TK-42 live color cameras. These are the new 4-tube cameras with 4 1/2-inch I.O. for luminance channel.

Presently installed are two video tape machines, a TR-22 TV Tape Recorder and a TR-3 Playback unit. Color can be recorded on the TR-22 and may be played for broadcast or checking on the TR-3. Tape facilities to be added in the new

building will provide a system for recording, playing, and editing at the same time — without closing down on any service while performing the others.

Three TS-40 Transistorized Switching Systems will be installed. One is for master control, the other two for the studios. This permits each studio to become a completely independent operation. Either or both of these two duplicate control facilities may feed master, or be operated directly into the STL to the transmitter. In addition, three TA-60/66 Electronic Special Effects Systems are being procured to provide each control center with complete creative effects for color productions.

All the switching and effects equipments are being installed in RCA's "New Look" consoles. Together with matching consoles for live and film cameras, these new designs will add a striking touch to the appearance of the layout. Since master control, studio control and program control are all in one large area, this is an important consideration for convenience of operating personnel. In addition, these beautifully-styled and matched equipments provide a striking image of the station.

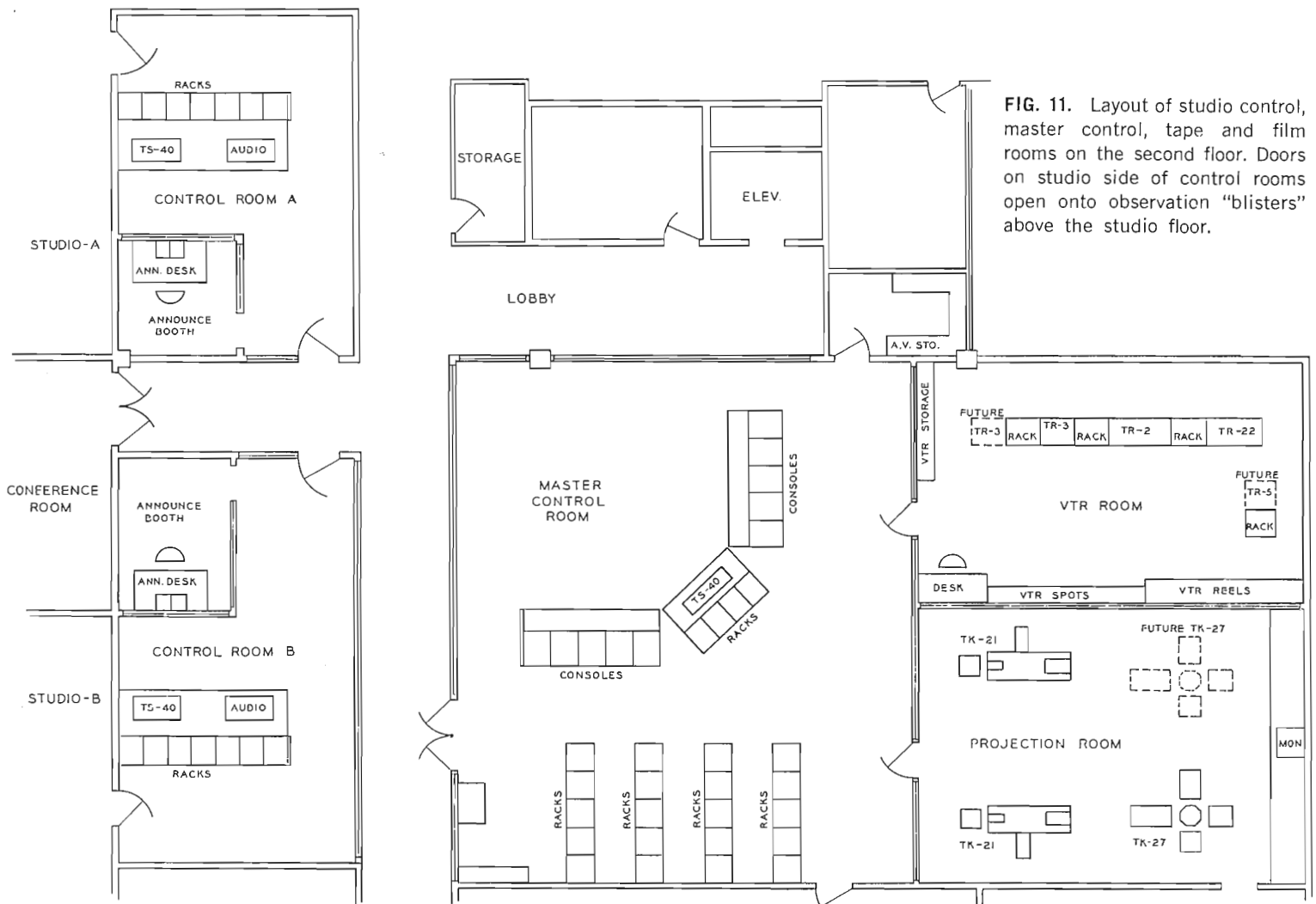
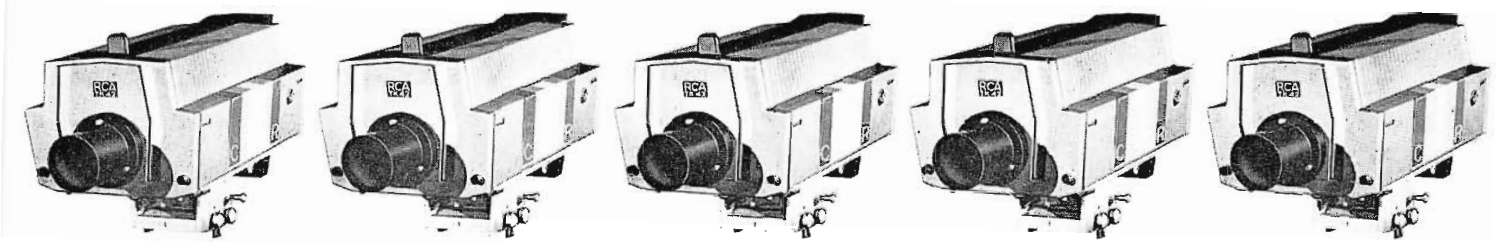

FIG. 11. Layout of studio control, master control, tape and film rooms on the second floor. Doors on studio side of control rooms open onto observation "blisters" above the studio floor.



TK-42 LIVE COLOR CAMERAS



TK-27 COLOR FILM SYSTEMS

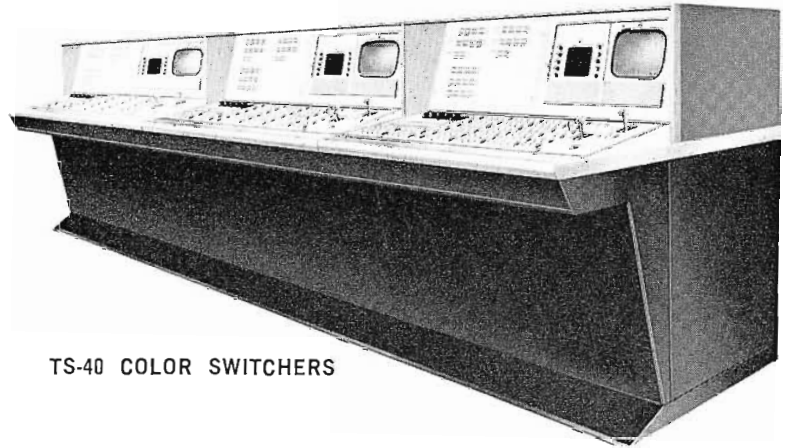

TS-40 COLOR SWITCHERS

FIG. 12.

**MATCHED
COLOR TV
EQUIPMENT**

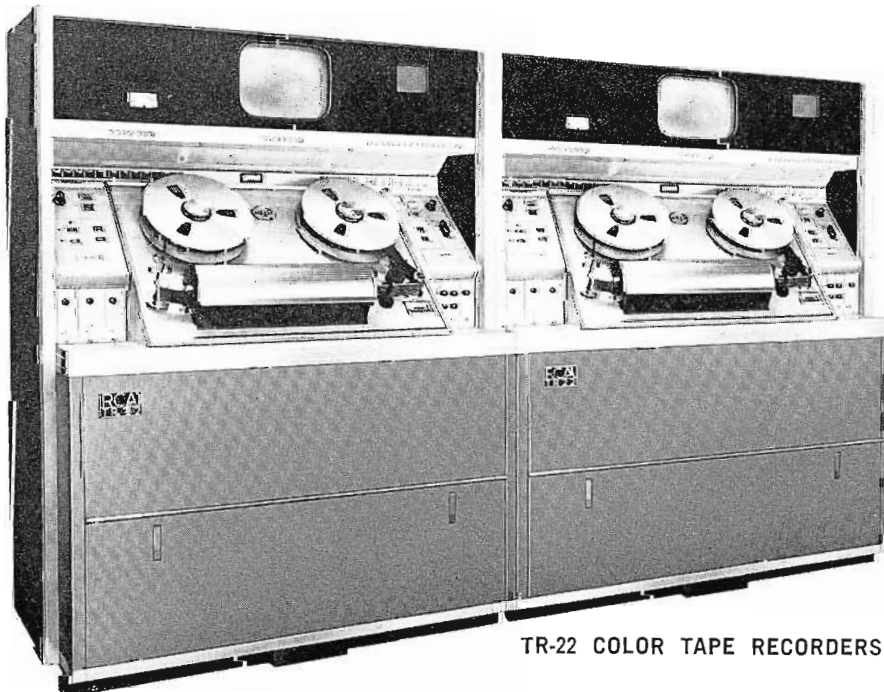

TR-22 COLOR TAPE RECORDERS

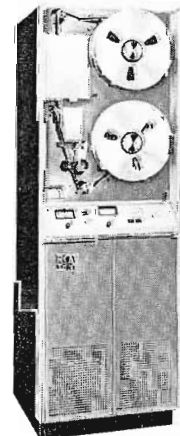

TR-3 COLOR TAPE PLAYER

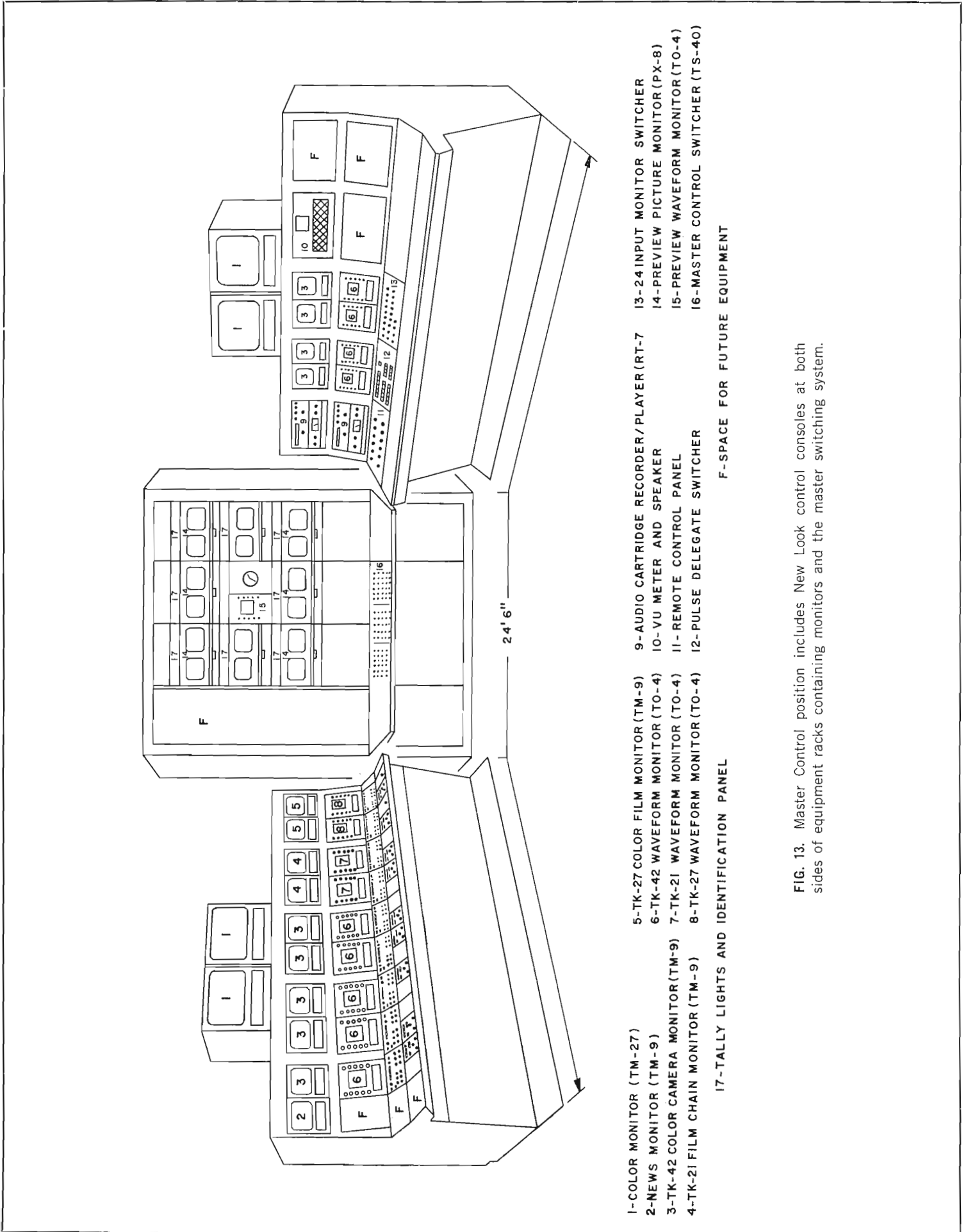

- 1-COLOR MONITOR (TM-27)
- 2-NEWS MONITOR (TM-9)
- 3-TK-42 COLOR CAMERA MONITOR (TM-9)
- 4-TK-21 FILM CHAIN MONITOR (TM-9)
- 5-TK-27 COLOR FILM MONITOR (TM-9)
- 6-TK-42 WAVEFORM MONITOR (TO-4)
- 7-TK-21 WAVEFORM MONITOR (TO-4)
- 8-TK-27 WAVEFORM MONITOR (TO-4)
- 9-AUDIO CARTRIDGE RECORDER/PLAYER (RT-7)
- 10-VU METER AND SPEAKER
- 11-REMOTE CONTROL PANEL
- 12-PULSE DELEGATE SWITCHER
- 13-24 INPUT MONITOR SWITCHER
- 14-PREVIEW PICTURE MONITOR (PX-8)
- 15-PREVIEW WAVEFORM MONITOR (TO-4)
- 16-MASTER CONTROL SWITCHER
- 17-TALLY LIGHTS AND IDENTIFICATION PANEL

F-SPACE FOR FUTURE EQUIPMENT

FIG. 13. Master Control position includes New Look control consoles at both sides of equipment racks containing monitors and the master switching system.

FIG. 14. Diagram of TS-40 studio switching and special effects system.

Sync Signal Switcher

Another feature of the equipment lineup is a solid-state pulse-delegate switcher. This device permits an operator to make an instantaneous switch to an alternate sync generator should signals from the main sync source fail or for some reason have to be interrupted. It thus maximizes the reliability of the station's video signal.

Through this switcher, for example, network sync that may be momentarily lost through remote technical difficulties can be quickly supplanted by sync signals from the local generator, avoiding program interruption. It may also prevent complete disruption of important taping operations.

The switcher can also facilitate station maintenance and alteration work. The operator can delegate standby sync for operating studios, cameras or tape systems while tests or modifications are being made in other areas of the system.

Transfer of individual studio cameras, film and tape machines is made by an attractive pushbutton control panel mounted in master control. Pushbuttons are illuminated, alternate action types that indicate which of the two sync generators is in use by each program source. A diagram of the pulse delegate switcher is shown in Fig. 15.

The switcher is styled much like a standard DA and employs a plug-in module to do the actual switching. It utilizes a total of 67 transistor crosspoints four of which are spares. Inputs are the six signals from each of the two sync generators: vertical and horizontal deflection signals, burst flag, subcarrier, blanking and sync. Outputs are connected to program sources, control room switchers, black burst amplifiers, colorplexer and test signal generator. As shown, burst flag and subcarrier are not required for the monochrome tape machines and cameras. Also, deflection circuits are built into the TK-42 color studio cameras, the TK-21 monochrome and TK-27 color film cameras as well as in the new TR Series of tape recorders, so that no vertical and horizontal drive signals are required for these equipments.

FIG. 15. Diagram of pulse delegate switching system which permits remote selection of either one of two sync generators.

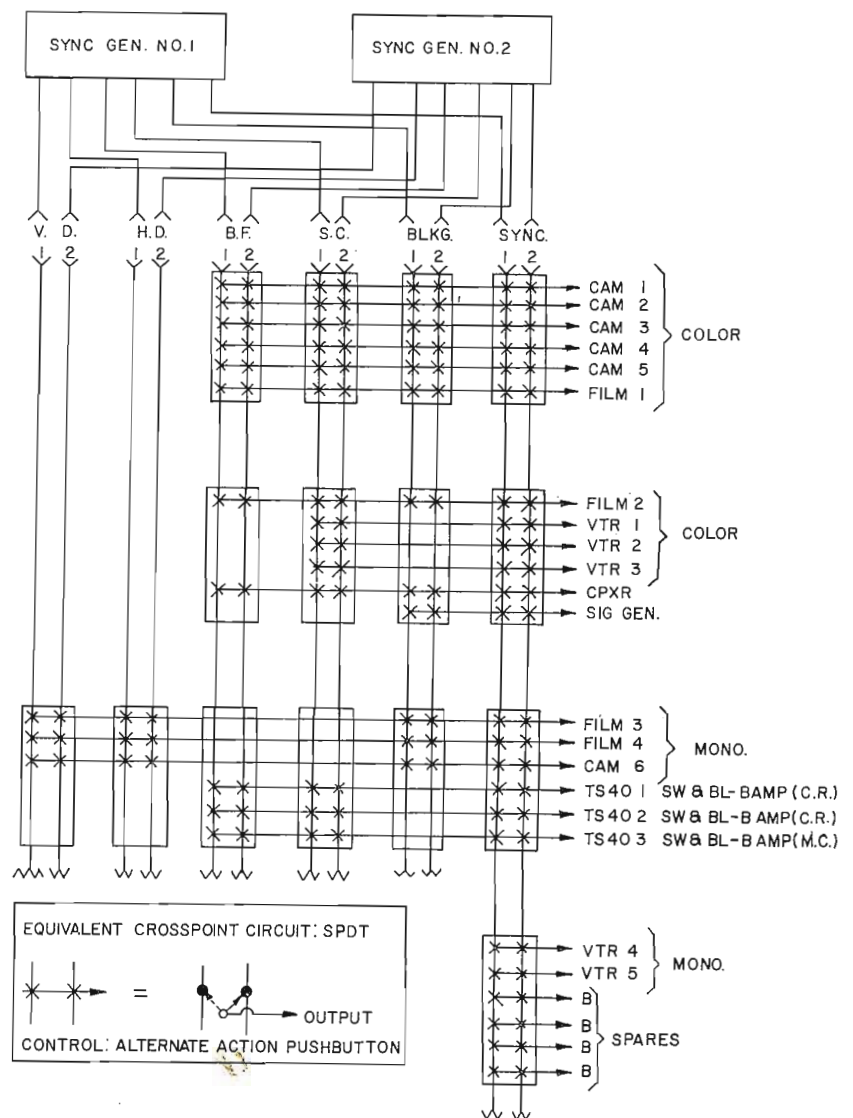
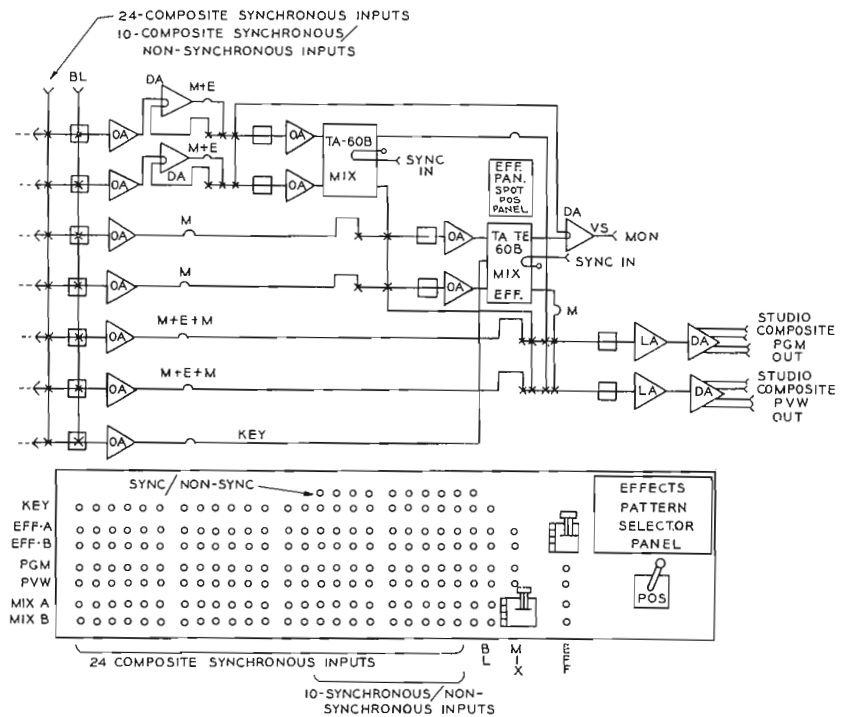

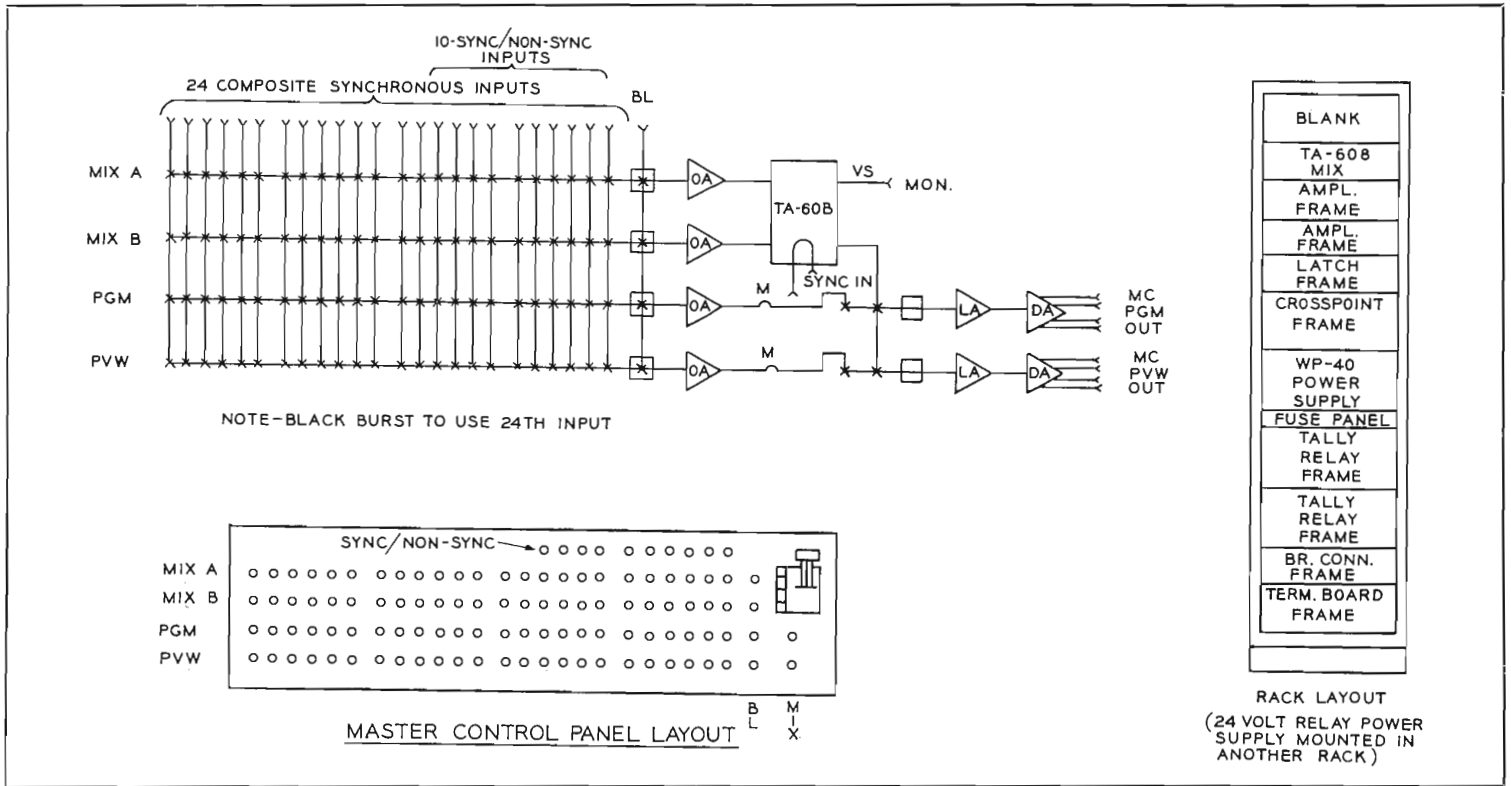

FIG. 16. Functional diagram and rack layout of TS-40 master control switching system.



FIG. 17. TR-3 tape player is indispensable in color taping operations.



FIG. 18. TR-22 tape recorder modified to permit frequent transporting of equipment in TV mobile unit. A monitoring section duplicating that shown here (at top) is permanently mounted in mobile van.



FIG. 19. Production personnel discuss new quartz lighting equipment.

Color Video Tape Center

According to Mr. Gerald McNulty, production manager, WLBW-TV proposes to become the video tape center of the South.

To this end complete complements of color effects equipment and electronic rear screen projection equipment have been procured. The basic background in the largest of the new studios will be a 3-cornered giant Cyclorama 140 foot long. This will make it possible to make several set-ups for back-to-back production cycles. By not constantly breaking down and setting up again a highly efficient operation is envisaged. Scenery will fly into place and lights will be permanently arranged for standby sets.

In preparation for color taping of programs and commercials, a three point program is in progress: (1) Color testing is being administered to all personnel responsible for decisions affecting production to ascertain their degree of color perception and thus assure quality control; (2) Fundamentals of color productions are being taught to production directors—including color filming, lighting for color, make-up and scenery basics; (3) With the assistance of the engineering department, technical equipment is being chosen and arranged to give independent control of each production, to give a wide range of creative devices and effects, and to provide the highest quality of color reproduction.

An integral part of this program is to pre-sell advertisers and agencies on the

ability of the station to produce color commercials and programs. Not only personal visits and displays of proposed facilities are being arranged but, more importantly, color clinics are being conceived. In these clinics, the production directors will present the mechanism of Color TV creations by means of actual demonstrations, both live in the studio and via closed circuit on monitors, then afterward by tape playback.

New World of Programming and Production

The new facilities will open up a new world of flexibility according to Mr. William Latham, Chief Engineer, especially for video taping. At present, there is one small studio whereas the new building will have two studios so that taping and on-air production may be done simultaneously. Previously production had to stop a show in the middle to do a station break.

The problems associated with a one-studio operation led to choice of two studios. With taping and live production going on at the same time in one studio, the format of the show frequently had to be altered in order to get taping done on schedule. One studio with many people trying to do several things at once has not been found conducive to the best results.

Today's single studio is 30 by 40 ft. with 14 ft. ceiling. Tomorrow's studios are: (1) 30 by 40 ft. with 19 ft. to catwalk; and (2) 60 by 70 ft. with 26 ft.

ceiling. New lighting arrangements are included. These new fixtures are arranged for pre-setting of specific lighting patterns which can be called for at will. In the main studio, there is room for four scenery set-ups, in front of the all-around cyc, each of which may be rolled into position or rolled out, as desired. This gives the director the kind of flexibility that speeds smooth production.

Breakthrough for Color Advertisers

As a result of the station's plunge into color, sales manager Charles J. Mathews reports that WLBW-TV has broken the ice with department stores in the area. On a special basis, the station is now producing color film commercials for Burdine's and for Richard's. Local commercials for Sears, Roebuck & Co., and for Jordan Marsh are being made on video tape. Plans are in the offing to make the station a center for production of color programs and commercials.

Conclusion

With a layout that is functionally designed for efficient traffic flow, WLBW-TV is proceeding with construction of a new building that will make Channel 10 Television City in Miami a thing to behold. With creative arrangements for programming local live color, taping of color programs and commercials, production of color films, and feeding the ABC-TV network, this station is a key part of the Florida television empire.

TWO SAN JUAN TV STATIONS SHARE SAME SUPERTURNSTILE ANTENNA

Single TF-6BM to Serve Ch. 4 and Ch. 6 Simultaneously

by B. K. KELLOM
VHF Antenna Product Analyst

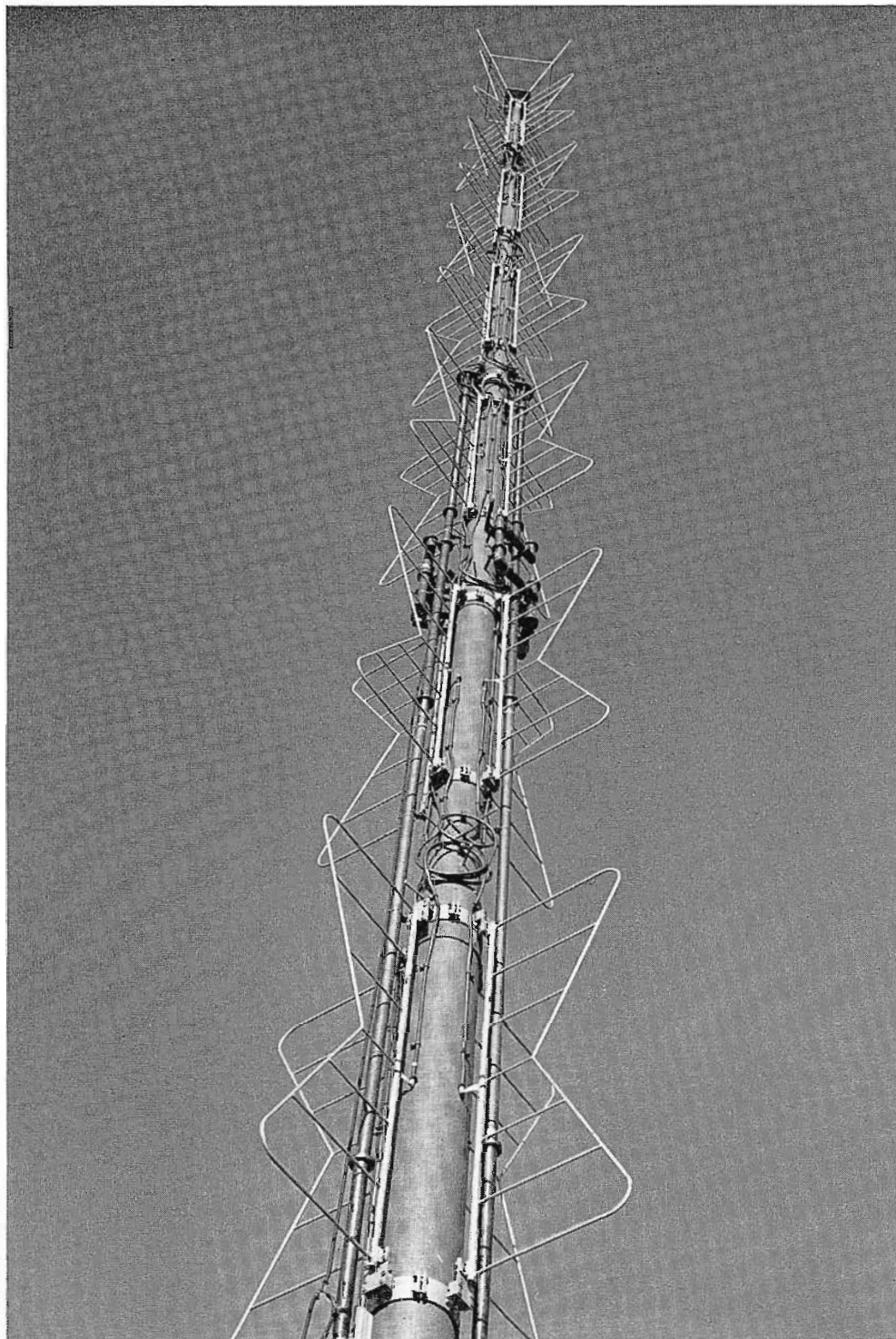

When Puerto Rican stations WAPA-TV and WIPR-TV begin operations early this year at their new Cerro la Santa site, they will diplex their transmitters into the same six-section Superturnstile antenna, thereby eliminating the need for a second tower and antenna. The installation will become RCA's fourth to operate with a common Superturnstile. WIPR-TV is an educational station, WAPA-TV a regular commercial operation.

Common Antenna Benefits Both Stations

Economy was a key factor in the birth of the new stations' antenna system. The use of a common antenna will save the two stations about half the combined cost of an antenna and 1000-foot mountain-top tower. In addition, there is a significant reduction in maintenance expense.

Neither station will sacrifice performance, effective antenna height, power gain, coverage or picture quality. All important aspects will be the same for both stations as if individual antennas and towers were used. This has been proven by the success of predecessor diplexing installations in Rochester, Mexico City, and Dallas.

The Basic System

Components of the diplexed Superturnstile antenna system are illustrated in Fig. 2. Filterplexers accept both the aural and visual signals from the transmitters of the two stations and diplex them onto sepa-



FIG. 1. Diplexing permits both stations to use entire six-section Superturnstile.

rate 3 1/8-inch Teflon-insulated copper transmission lines. At the tower top, the Ch. 4 and Ch. 6 signals are then fed through isolators to a broadband combiner, which diplexes both channels on the feedlines to the East-West and North-South antenna elements of the Superturnstile.

Superturnstile Ideal Antenna

The antenna to be shared is a conventional Type TF-6BM six-bay Superturnstile designed for operation on Channels 4, 5 and 6. Only slight modification of the antenna was required to optimize operation on Channels 4 and 6. Because of the high salt content of the atmosphere in which the antenna will be used, copper Styroflex feedlines were used in place of the standard aluminum feedlines. The antenna-tower installation is designed for a wind load of 90 psf.

The Superturnstile is ideal for diplexed operation. It is inherently a broadband antenna with high power capabilities and excellent impedance characteristics. One other important attribute is the uniform coverage pattern. Quadrature fed E-W and N-S radiator elements provide a horizontal radiation pattern with a circularity approaching one db.

High Degree of Isolation

A unique element of the system is the broadband combiner shown in Fig. 3. This

FIG. 2. Block diagram of diplexed antenna system.

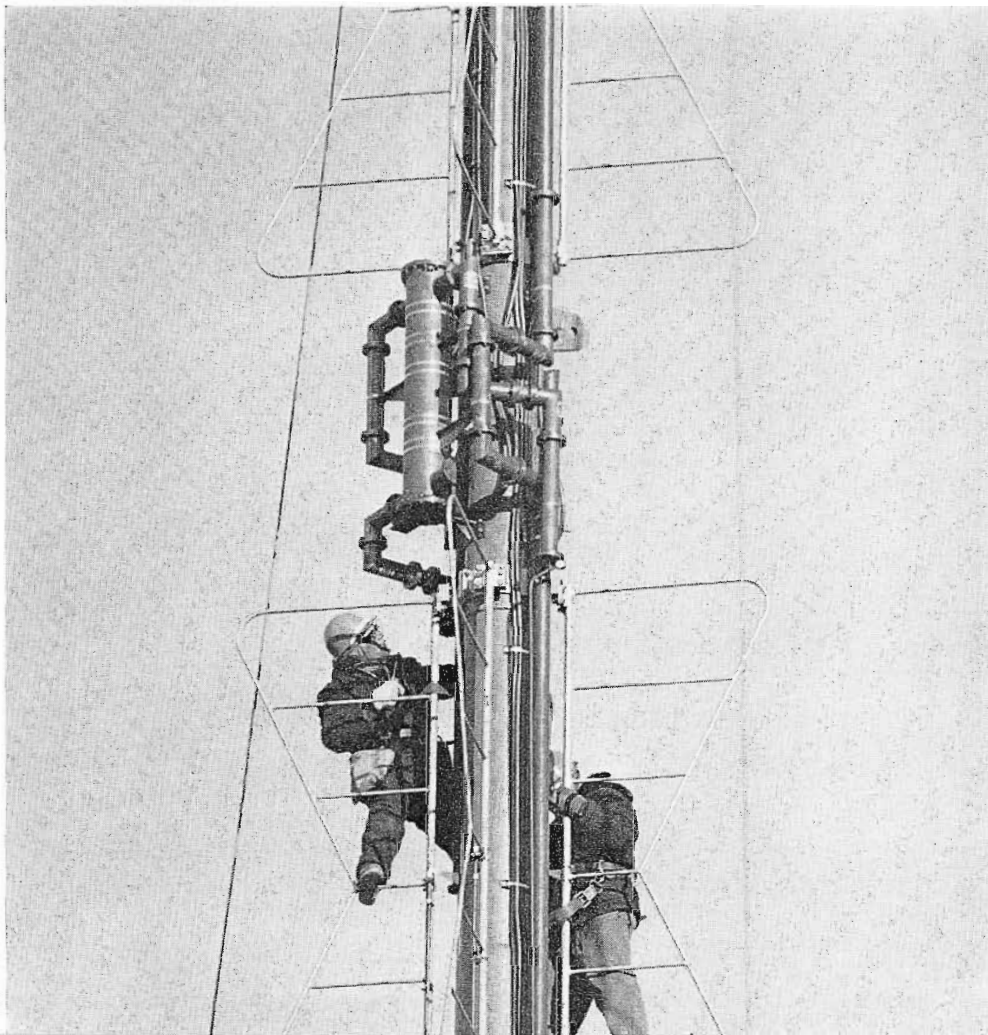
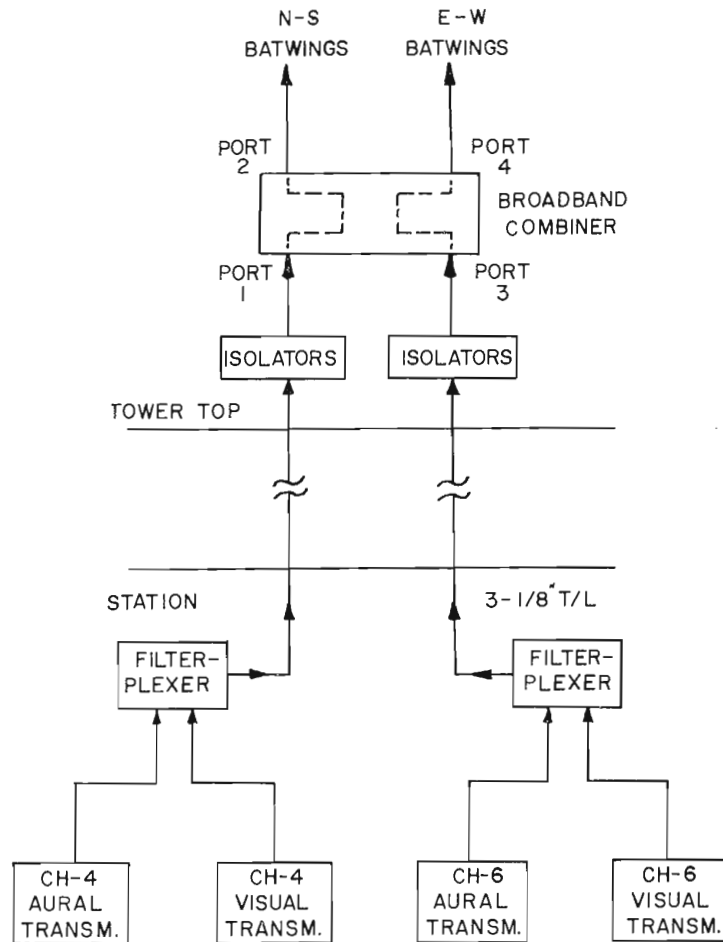

unit consists of transmission line sections that combine the diplexed outputs of the Ch. 4 and Ch. 6 transmitters and applies equal amounts of the combined energy, displaced 90 degrees in phase, to the E-W and N-S sections of the antenna.

Offering virtually no insertion loss, the combiner has two input ports and two output ports. Diplexed aural and visual signals from the Ch. 4 transmitter enter Port 1 and flow to Port 2. In so doing, half the energy is coupled to the parallel circuit and appears at output Port 4. In like manner, energy fed into Port 3 from the Ch. 6 transmitter is split equally between Ports 2 and 4. Thus, these two ports deliver combined energy from both transmitters to the E-W and N-S sections of the antenna. (See Fig. 2.)

Another design feature of the combiner is its excellent isolation between inputs from the two transmitters. In addition,

FIG. 3. Ch 4 and Ch 6 signals are diplexed by the combiner, a transmission line assembly mounted near the middle of the antenna.

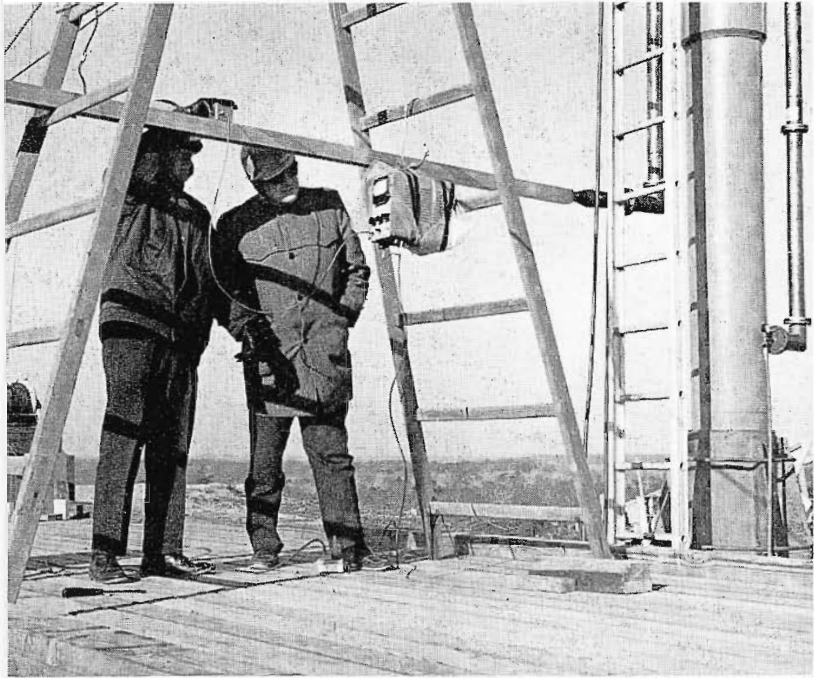

FIG. 4. RCA engineers measure VSWR during tests of diplexed TF-6BM antenna.

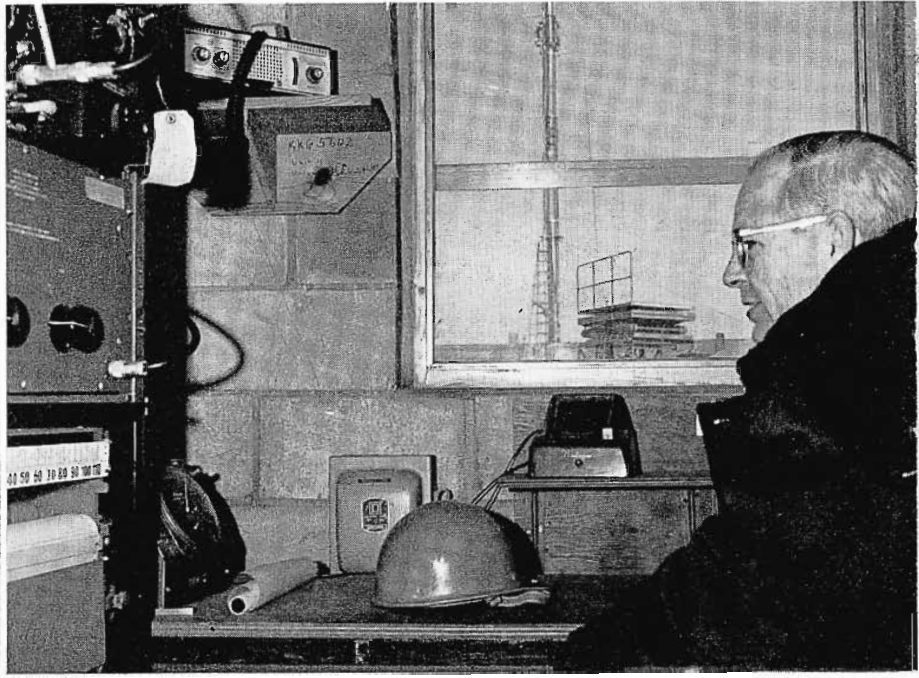

FIG. 5. Field strength measurements being recorded on strip chart in antenna test house.

isolators in the form of band-pass/band reject couplers in each output line provide virtually complete isolation so that for practical purposes each transmitter sees only the antenna as a load.

Antenna Testing

After fabrication and assembly, the antenna was mounted on a turntable at the RCA antenna test site in Gibbsboro, New Jersey, and extensively tested for compliance with pattern requirements, adjusted for optimum input VSWR, and tested for isolation between operating channels.

Tests take place with the antenna being rotated, first while mounted on the turntable horizontally, then mounted in a vertical position. For utmost accuracy in plotting radiation patterns, measurements are made with the antenna serving as a receiving device. Test signals are beamed at the antenna from a transmitter 2.5 miles away from the knoll on which the turntable is located.

Radiation pattern tests produced typical circular coverage plots for the given channels as illustrated in Fig. 6. VSWR measured less than 1.1 at both channels, and 33 db isolation was recorded between transmitter inputs at the combiner.

Installation of the antenna will be made atop a 1000-foot guyed tower designed for a 90 psf wind load to withstand a wind velocity of 147 MPH.

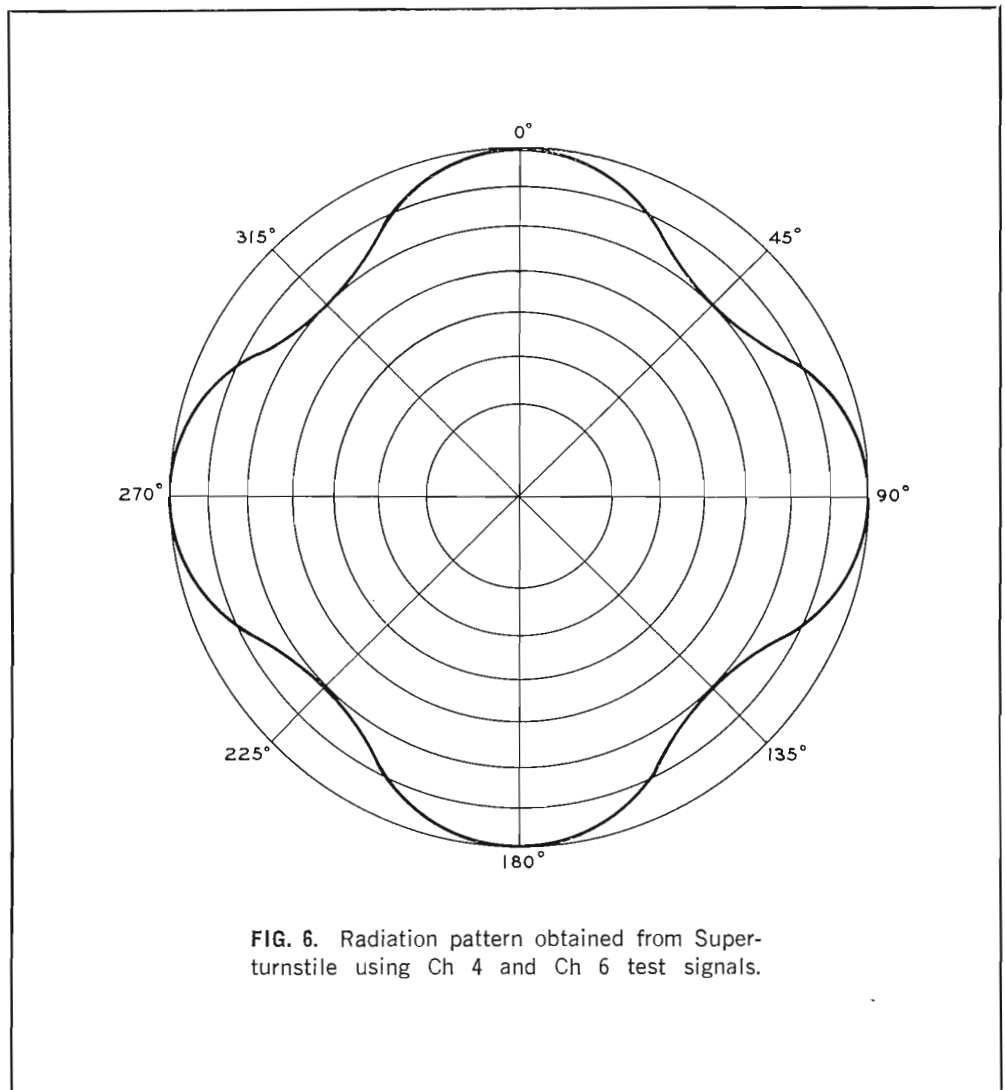

FIG. 6. Radiation pattern obtained from Superturnstile using Ch 4 and Ch 6 test signals.

DUAL PATTERN CAPABILITY OF THE S-T

The WAPA-TV, WIPR-TV Superturnstile antenna was first designed with a built-in capability for radiating two different patterns—the normal omni pattern for Ch. 6 and a “peanut” directional pattern for Ch. 4. The directional signal was necessary to meet an FCC suppression requirement (at the time tentative) in the Ch. 4 construction permit. Since this requirement was tentative, the need for omni directional radiation of the Ch. 4 signal also existed.

Therefore, design of the antenna envisioned temporary directional operation for the Ch. 4 signal with the provision for changing to omni directional operation with a minimum rearrangement of antenna components.

The calculated horizontal field patterns can be seen in Fig. 7, which shows the

patterns produced simultaneously for the two channels by the single antenna. The elongated Ch. 4 pattern has a maximum-to-minimum of 6 db, and the Ch. 6 pattern exhibits a non-circularity of only one db. Prior to shipping the antenna, however, WAPA-TV received permission to operate with an omni-directional horizontal pattern, so the minor changes (actually, only a small change in the length of a section of line) were made in the antenna to produce the circular pattern.

Achieving Directivity

The Superturnstile is well adapted to achieving good directivity with minimum effort by virtue of the built-in and independent feedline configuration, which is most convenient for pattern shaping.

Normally, the East-West and North-South radiating elements are fed in phase

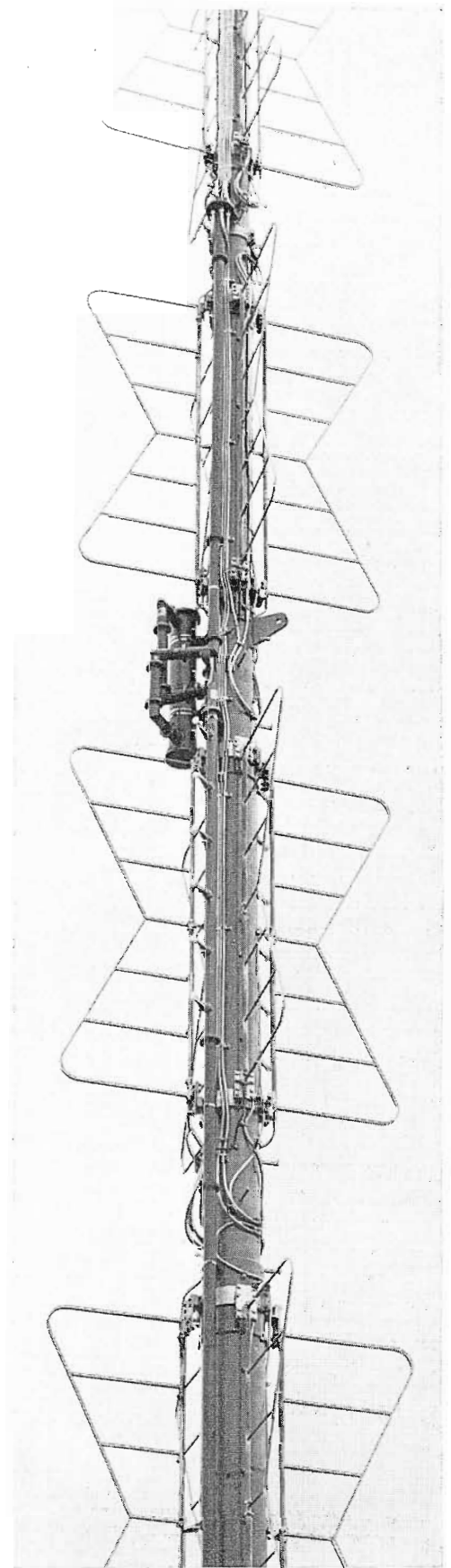
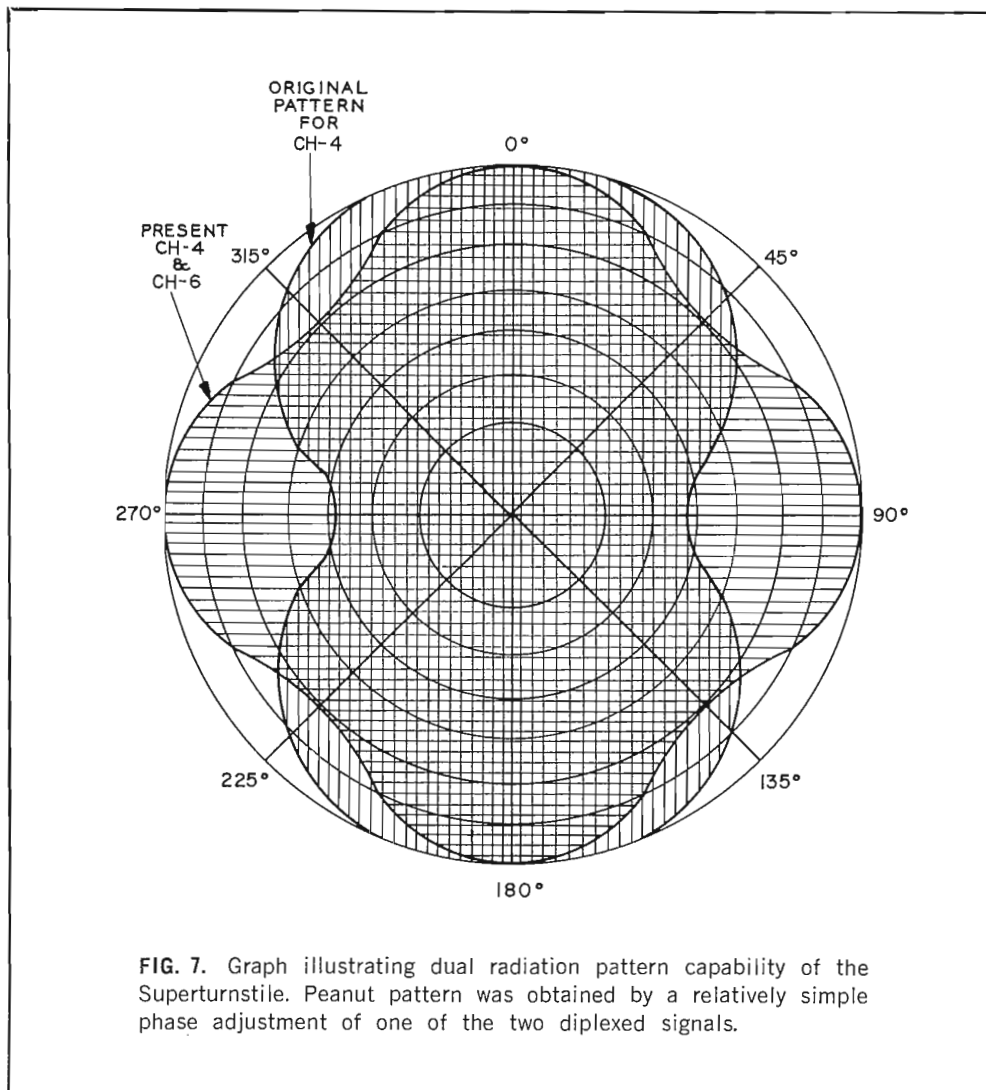

FIG. 8. View of antenna showing rigid 3/8-inch transmission lines feeding the combiner (center), and 7/8-inch Styroflex lines that feed batwing elements.

quadrature. This produces the circular radiation pattern. In the case of the diplexed Ch. 4 and Ch. 6 signals of the WAPA-TV, WIPR-TV antenna, both signals were fed from the combiner to the batwings in phase quadrature to obtain circular patterns for each signal, maximums and minimums coinciding. The directional pattern for the Ch 4 signal was obtained in two ways, first by properly orienting the antenna so the minimums would be in the right azimuth locations, then by adjusting the phasing of the Ch. 4 signals applied to the E-W and N-S systems to achieve the desired radiated pattern shape. The Superturnstile produces the different patterns independently and without interference to one another.

Conclusions

WAPA-TV and WIPR-TV will benefit from their common tower and antenna by eliminating the cost and maintenance of separate towers and antennas. Because both use the same radiator, effective antenna height for both stations will be the same. Performance of the diplexed antenna will in no way be inferior to that obtained from separate antennas.

Advantages of the technique are too numerous and important to overlook, and there are presently many other stations considering this type operation. As TV stations multiply and restrictions on the number and height of towers increase, antenna-sharing in the near future may very well become common practice.

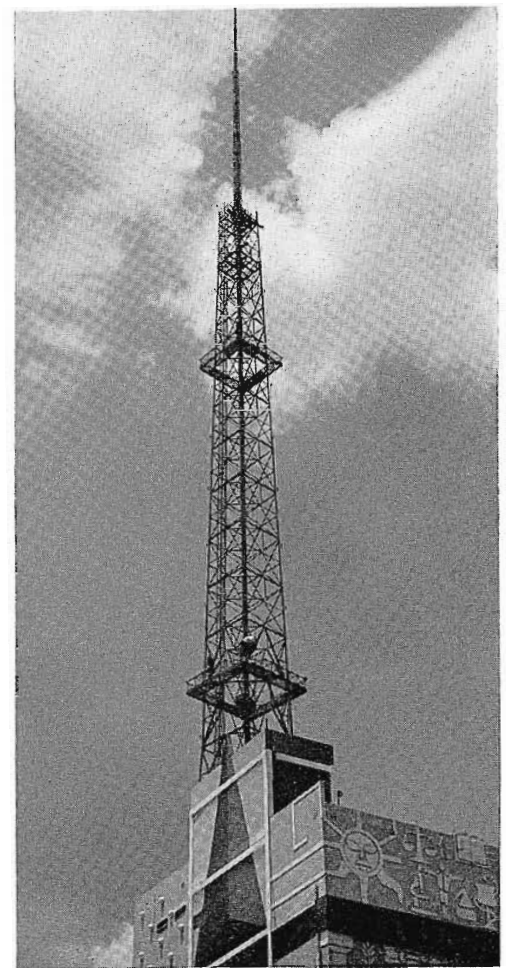

FIG. 9. Mexico City TV tower supports diplexed four-section Superturnstile for Channels 4 and 5.

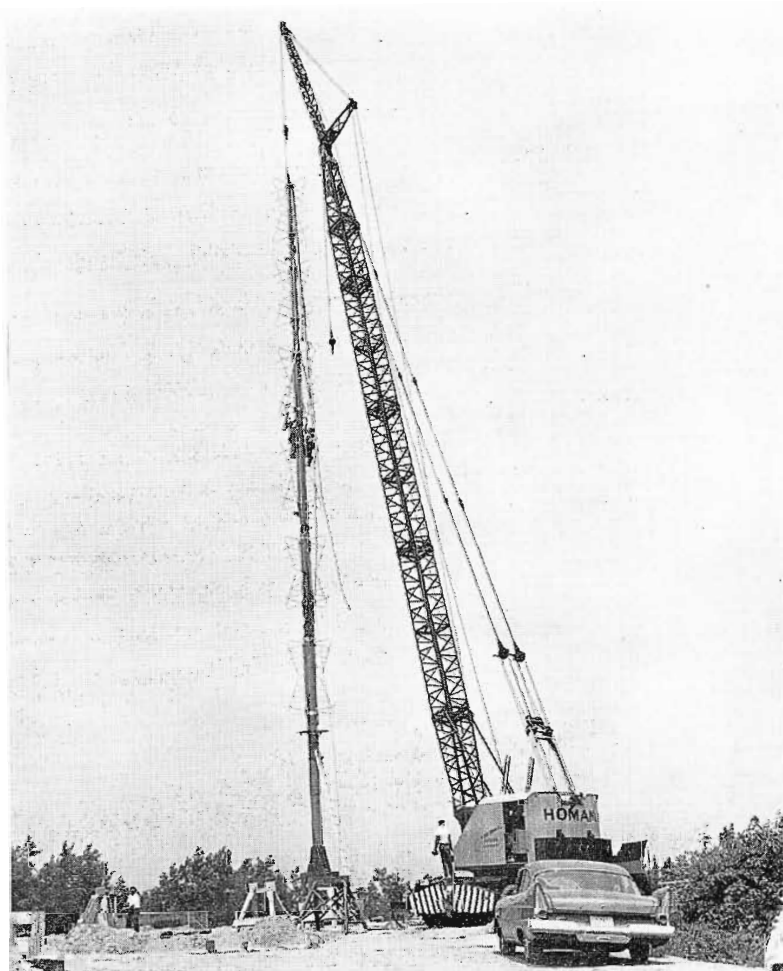

FIG. 10. Six-section S-T shown being set up for testing prior to erection in Dallas to serve Ch 5 WBAP and Ch 4 KRLD.

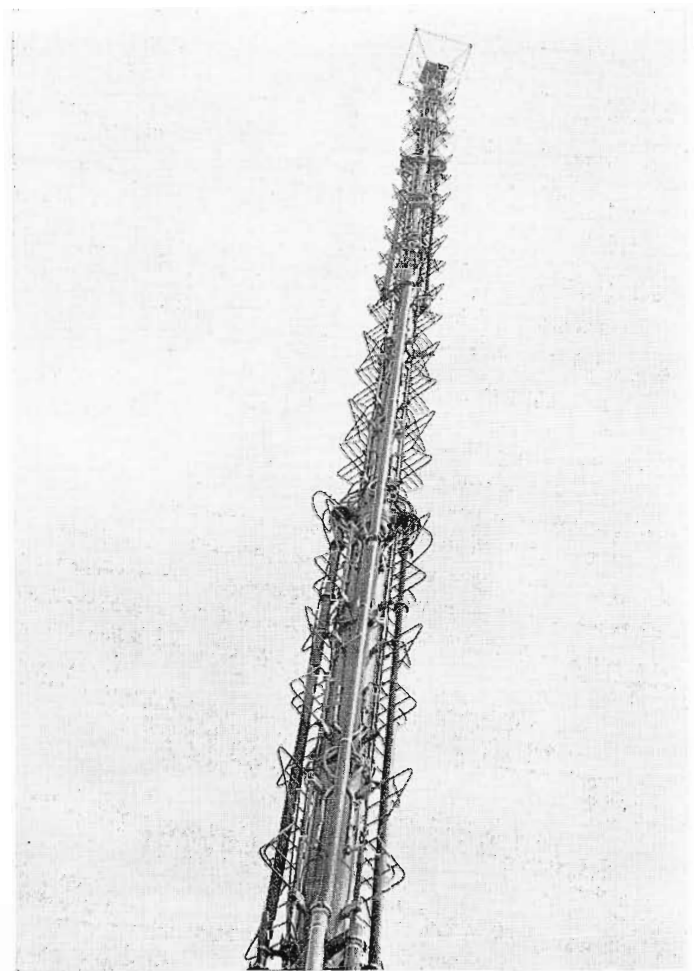

FIG. 11. Maximum power stations WHEC-TV and WROC-TV, Rochester, share this diplexed RCA TF-12BH 12-section S-T.

Putting the
TK-42 COLOR CAMERA
Through Its Paces
at 1966 NAB CONVENTION

The one color camera operated under widely varying conditions at the 1966 NAB convention was the TK-42. Live demonstration of the numerous features of this "Big Tube" Color Camera showed what the camera can do under normal and "problem" conditions.

The big 4½-inch image orthicon in this camera makes every color picture better . . . Flesh tones are vibrant and realistic over widely varying light levels. Silhouettes,

usually avoided with color cameras, are now possible. The green hair effect, caused by back light on dark-haired performers, is eliminated. Strong reflections (speculars) are handled without halo or flash. Color tracking is accurate down to the subtlest shades.

Photographs on these pages depict several of the scenes from the NAB demonstration. The captions for the pictures are taken from the script.

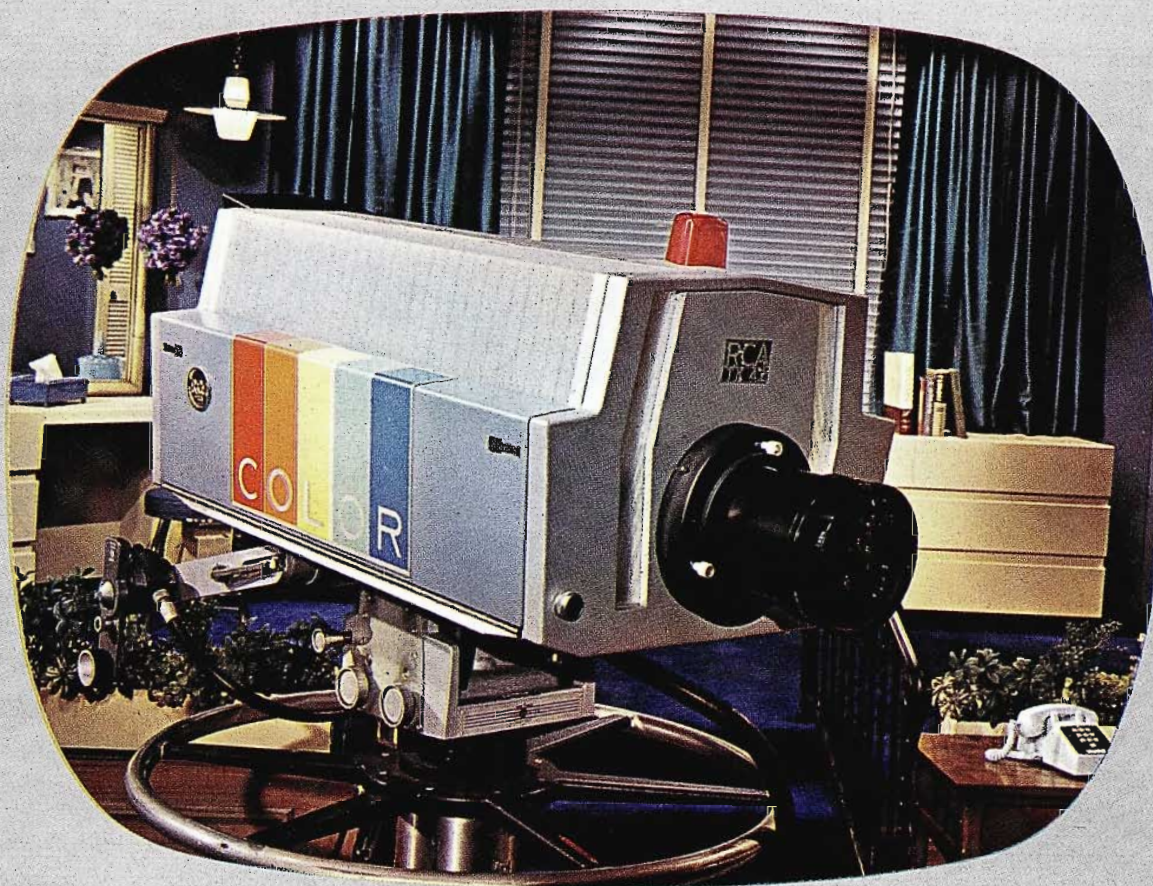

"Your date with the TK-42 begins. The "silhouette" has till now been an effect generally avoided. Notice how the TK-42 handles this low light level, with uniform shading in the low light areas. Notice particularly the color fidelity of the face. The light level of the face is in the neighborhood of 20 foot candles yet the camera is operating at f/8, which is the normal opening at 250 foot candles.



"In this area of our set the lighting from the front is all at 250 foot candles, but if the camera looks into the mirror, we see the face in light and shadow. The ratio of illumination on her face from lightest to darkest is 8 to 1. You are watching at this point a most critical test of color fidelity. The ability of a camera to faithfully reproduce skin tones in widely varying light levels.



"It has often been said that one picture is worth a thousand words. Compare now the live image with the monitors in this example of the sharpness and color fidelity of the TK-42 as it scans milady's dressing table.





"Although the video operator would normally make an adjustment of the iris to compensate for changes in scene lighting level, we wish here to show the ability of the camera to handle this change during the interval before the operator has been able to optimize the iris setting. Watch as our models pass through various light levels on the set.



"Milady's dress, in beaded white, is handled cleanly and beautifully by the TK-42. The scene here in under normal lighting.



"The jewelry reflects the light directly into the camera. The TK-42 is unique in its ability to handle "speculars" such as these, cleanly. The big four-and-a-half inch image orthicon makes the big difference here.

"Watch now as the candles are lit. The TK-42 handles this in color better than most monochrome cameras do in black-and-white. In a scene such as this specular highlights are often 50 times as bright as the overall lighting.



"Have you ever noticed that a dark-haired TV performer standing in strong backlight will appear to have green hair? Technically this green hair effect is called polarization. The TK-42 has eliminated this problem.



"There you have it. The TK-42 with its superior resolution, sensitivity, color fidelity and tracking ability. We hope that its specular response, remarkable ability to handle overloaded light and eliminate polarization has been amply demonstrated. The TK-42 is the BIG TUBE camera with the perfect color picture."



EDUCATIONAL TV STATIONS AND CONVERSION TO COLOR

by E. C. TRACY

*Division Vice-President
Broadcast and Television Products Sales Department*

EDITOR'S NOTE: *This is the complete text of an address by Mr. E. C. Tracy before the National Association of Educational Broadcasters at their annual convention November, 1965 in Washington, D.C.*

Today, we are witnessing an industry wide conversion to color of boom proportions. In the past few months, public interest in color television has developed to a high degree, although we at RCA have been in a position to support a general transition to color for about the past ten years. Now, to use the space age vernacular, all elements are "Go" and the conversion process in the U.S. domestic market is proceeding under forced draft.

The color transition greatly enhances our industry's ability to do certain things. With the added dimension of color we are in a much better position to inform, to entertain, to advertise and, to educate.

Those of you in charge of educational TV stations are directly effected by all of this. Most of you will soon be surrounded in your markets by full color commercial television . . . some of you are already. Undoubtedly, you will wish to become equal in impact in this new area. You've built your stations on the basis of technical equality with commercial broadcasters. You put out excellent signals. You use the best of equipment.

From conversations with some of your most experienced members, I have deduced that the ETV audience contains an "over average" number of intellectuals, primarily

because of the type of programming. There are a large number of professional people. There are the affluent and those in positions of leadership in industry and government. But note that these groups are those wherein color television has developed its highest "penetration." That point is important.

The equivalent "audience rating" is the measure of achievement for an ETV station and this factor may determine operating income for certain stations.

Taken all together, it may be more important for an ETV station to become involved in color than it is for its com-

petitive commercial telecaster. Educational stations need the "proven pulling power" of color programming to maintain or to enhance the hard-won audience position they now enjoy.

Each station faces the necessity of evaluating conversion to color in some detail. It is quite impossible to quote a few simple cost figures in the hope that they will be meaningful. There are an almost infinite number of variables in determining what "going into color TV" means to the individual station, however, it is practical to discuss certain areas of interest in your further deliberations.

FIG. 1. The primary colors of television.

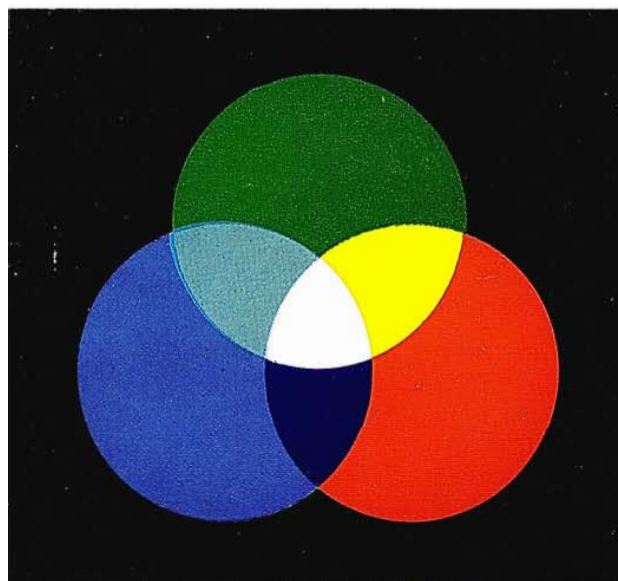

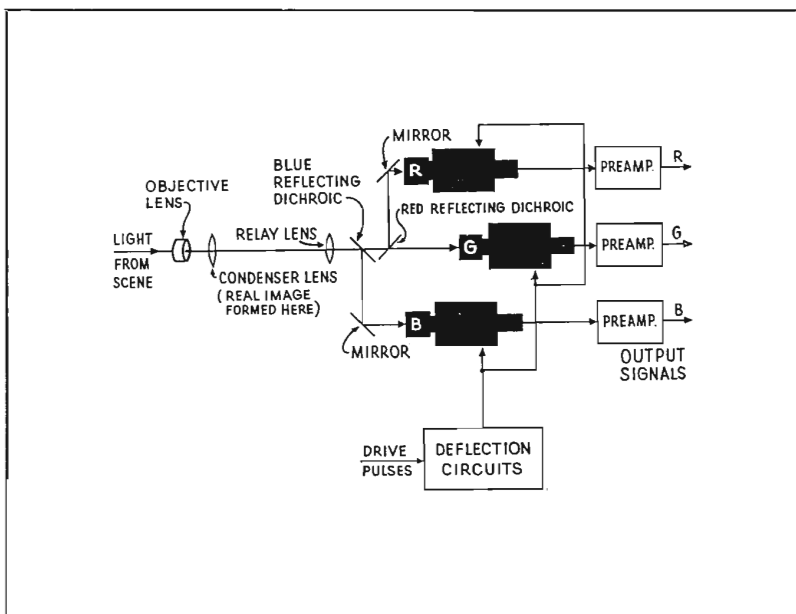

FIG. 2. Color camera components.

Four Areas for Discussion

I have selected four areas for general discussion, beginning with some basic technical facts and culminating in a recount of practical experience.

First, I think it is wise for you to have some idea of "what's under the hood." Of course, no one expects you to be a technical expert on the subject unless you have a particular bent in that direction.

Second, you should be informed with regard to new "tools" the industry has provided for colorcasting. New equipment available today simplifies the operation of what might otherwise be an almost impossibly complex system.

Third, I would like to review the conversion of a typical black and white station and provide some hints for your special attention so that you may apply these to your own case.

Fourth, I have accumulated some pertinent comments from ETV station managers who have been through the conversion to color, just for our general guidance.

PART I COLOR FUNDAMENTALS

I certainly shall not presume to conduct a technical course in color TV, but a few color fundamentals should be of interest to ETV station managers. In Fig. 1, you see the three primary colors used in color television—red, blue and green.

I wonder how many of you could properly label the three colors in overlapping

areas? One, of course, is yellow, but the other two in color TV parlance have the unusual designations of cyan and magenta.

The central area is of most importance in this discussion, where all three primaries overlap in additive fashion. Thus, this area is white, developed through the combination in proper proportion of the three primary colors.

Every object we see reflects light that can be separated into these three primary colors and, further, in a re-assembly process, can be superimposed upon each other to reproduce the original image—with con-

siderable accuracy. This process of separation permits the transmission of each color separately and its re-assembly at the receiver and is the basic physical concept upon which our color system operates. Let's go a step further into the process through an examination of the technical elements of the system.

The Color Camera

In Fig. 2, we have the block diagram of a color camera. Note that it consists of a red camera, a blue camera and a green camera; therefore, each television color camera is really a three camera device (you will hear later of the new four tube color camera, but let's stay with the basic three camera system for the time being). Here we make the acquaintance of the "dichroic" mirror, a device designed to reflect selected primary colors with great efficiency while at the same time, passing other colors through with very insignificant losses. By assembling blue and red dichroics as shown in the diagram, it is possible to separate the colors in the subject directing them to the appropriate color cameras. The full color image first loses its blue content by reflection from the blue dichroic which is then sent to the blue camera. Similarly, the red is separated and reflected to the red camera. The green, not having been deflected, passes straight through and impinges upon the green camera.

In Fig. 3, we have a sub-division of the original color, with red, blue, green, yellow, white and other colors in the little house. Parts of Fig. 3 show what each camera sees of the light signal after it goes through the

FIG. 3. R, G, B components of color image.



dichroics. The red camera sees only the reds. The blue camera sees only the blue components. The green camera sees the green components of the same picture. Now it's obvious that what we've done with our dichroic system is to take the picture apart and put it into three cameras, each of which records a basic primary color.

In Fig. 4, we see the next step in this process, where each of our three primary colors is converted to a corresponding signal voltage. Our red camera, for instance, will produce a red signal voltage whenever there is a primary red component in the color scene being passed through the dichroic system. Similar signal voltages are developed from the green and blue cameras. Taken all together, our color camera system has provided for us three electrical voltages which are completely descriptive of the color content of the original scene.

Encoding and Decoding

The complex of encoding and decoding a color signal is beyond the scope of this paper, but briefly stated the process involves:

- The matrixing of our three primary signal voltages to produce a "luminance" signal (M) and two color difference signals called (i) and (q).
- The two phase modulation of a color sub-carrier at 3.58 mcs. by the (i) and (q) signals.
- The transmission on the TV station carrier of the (M) signal and the two phase modulated sub-carrier simultaneously, and

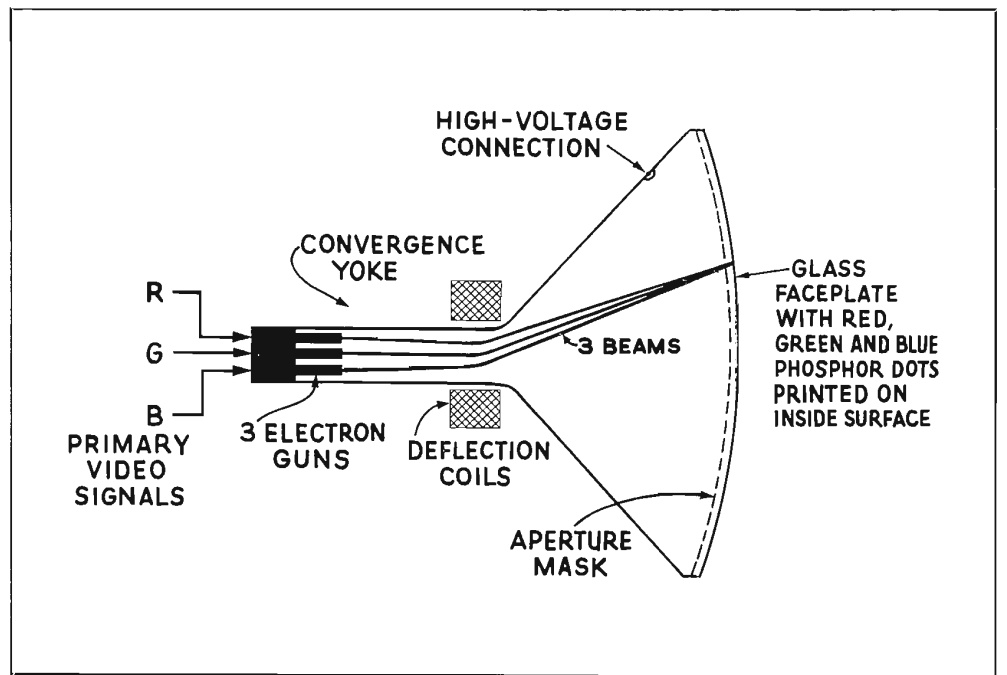

FIG. 5. Three-gun color kinescope.

- The recovery of the original color signals as derived from the camera through synchronous demodulation and re-assembly of the signal voltages at the receiver.

The important thing for the station manager to remember is that the color signal in all its rather considerable complexity must be handled throughout the station switching and distribution system to the transmitter plant and through the transmitter and antenna system with a very low order of degradation in order to preserve

the accurate color information originally derived from the camera. You should understand that your engineer must re-assess all of the equipment in your station through which these color signals pass to determine their individual and collective usability.

Color Kinescope

Figure 5 illustrates the means by which red, green and blue signals are re-assembled into a complete color picture. Most receivers today use a so-called "shadow mask" tube, which in my opinion is one of the real marvels of our electronic age. Note the three electronic guns, a red, a green and a blue gun—each producing an electronic beam under the influence of the magnetic fields produced by the yokes. These beams are focused on the glass plate at the viewing end of the tube, which contains a myriad of red, green and blue phosphor dots. A mask about one-half inch behind the phosphored area is perforated with tiny holes so placed that the beam from the red gun, for instance, is shadowed from the blue and green dots and impinges only on the red dots on the phosphor surface. Similarly, the green gun impinges only on the green dots and so also for the blue.

In Fig. 6 we have a reproduction of what you would see if you were to take a magnifying glass and look closely at the screen of the picture tube. You will actually be able to see red, blue and green dots and you will notice that you're getting a white signal from the combination of the three

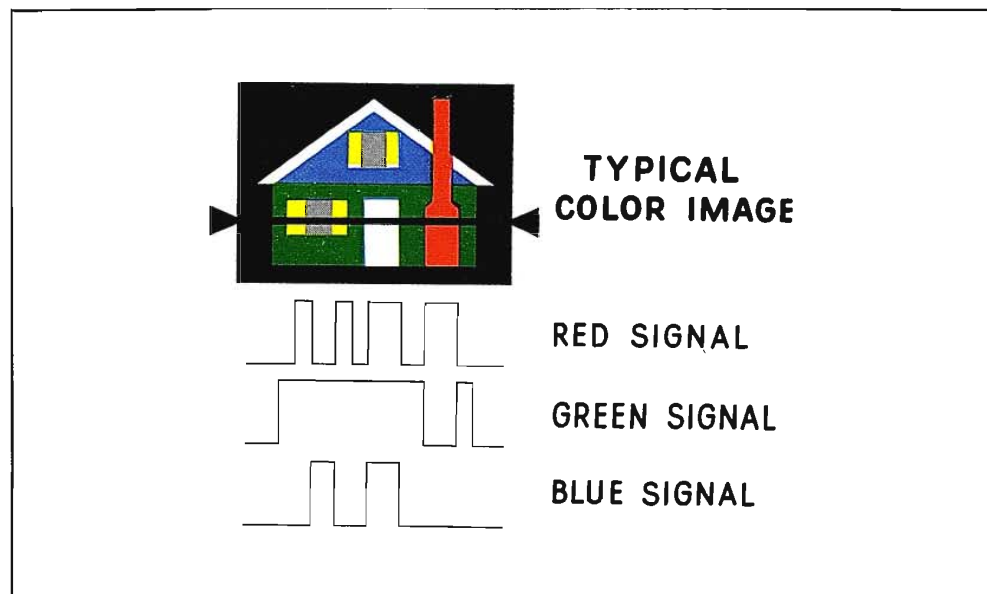

FIG. 4. Signal voltages from typical color image.

colors. So the re-assembly process brings us back to where we started. On the face of the kinescope there actually appears for this subject a red image, a blue image and a green image and by super-position the original is reproduced.

Now that's a pretty fast way of going through a whole color television system and my apologies to the engineers, but I do think you ought to know about the three tube system basically, about the way the camera breaks down the primary colors, and about the way they're re-assembled in the kinescope. I hope that there may be a little satisfaction for you in that. So much for our review of primary fundamentals for the manager.

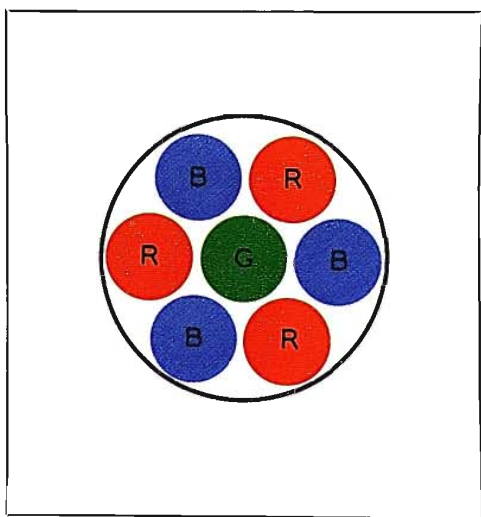

FIG. 6. Magnification of color kinescope phosphor dots.



FIG. 7. Four parameters of modern TV equipment.

PART II COLOR TV EQUIPMENT

The next part of this discussion has to do with the "tools" for telecasting in color. Industry has been working for a long time with new developments and has produced some very remarkable results, making the current job easier for all of us. In Fig. 7, we see the four parameters used in RCA's "new look" line of equipment. The "solid state" transition in broadcast equipment has been in the process for quite a number of years and everyone knows what transistorization means; however, I would like to point out that truly modern designs take full advantage of no less than four parameters, only one of which is transistorization. It is my suggestion that with the help of your engineering department, you evaluate how well these parameters have been incorporated when you evaluate new color equipment for your station.

Basically, transistors make possible the design of small and reliable circuit elements. General advantages in terms of reduced power consumption and reduced maintenance requirements are well known.

Modularizing means sub-dividing, putting into small unit sections the circuitry that it takes to perform certain functions. Modules can be tremendously helpful, providing flexibility in handling equipment, and in inter-changeability. Modular construction is so important that RCA uses it in all its latest color TV equipment.

Stabilization reflects the degree to which engineering skill and effort has been put forth to provide non-critical, easily maintainable solid state circuitry. An engineering term, it has to do with use of feedback circuitry, non-critical selection of transistors, avoidance of critical circuitry and the like. The stability of transistorized equipment is a measure of the excellence of the engineering design itself.

Standardization implies a capability for using the same module in a multiplicity of positions in the equipment layout. You can visualize a station having a dozen or more positions for a single module. There must be many module types as each must perform a separate basic function. Standardization promotes circuit familiarity and assists greatly in the rapidity with which repair or replacement can be accomplished, thereby reducing the cost and complexity of an equipment maintenance program.

Only the manufacturer who utilizes all of these foregoing design elements can provide maximum value and a maximum useful life during this current period of changing designs and rapid obsolescence.

Having reviewed this four element design concept, we may review a few of the major items available from RCA in which they are incorporated.

Switching and Effects

First, Fig. 8 shows a control panel for an RCA TS-40 Switching system. I hope some of you are fortunate enough to face the color transition equipped with one or

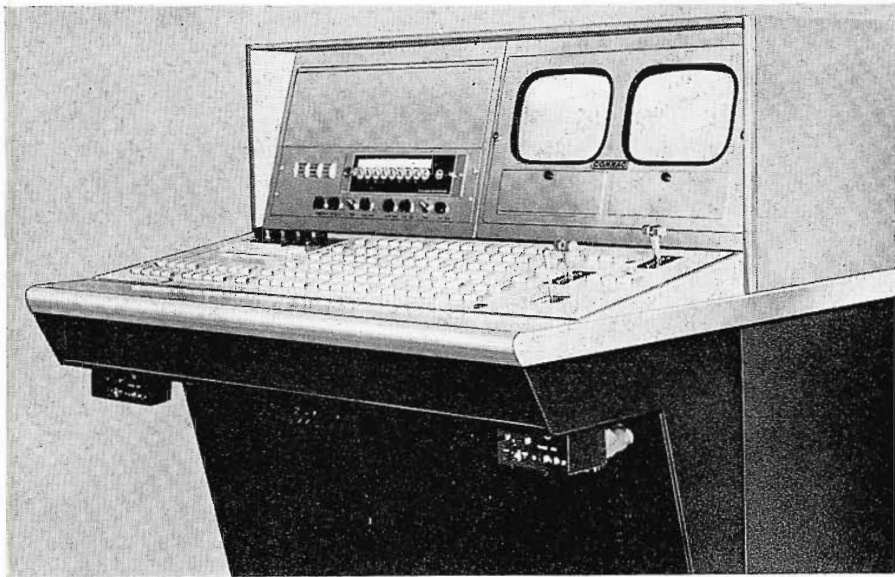

FIG. 8. TS-40 Switching System.

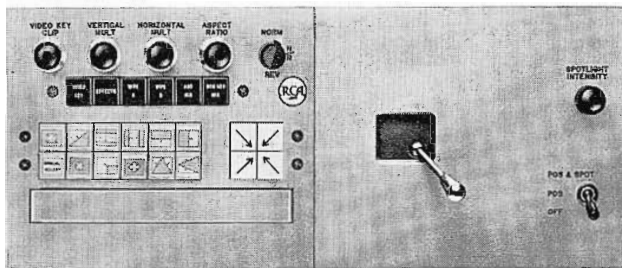

FIG. 9. Mixing and Effects Panel.

FIG. 10. TK-27 Color Film System.



more of these systems in your station. Well proven and popular for many years, the TS-40 was the first completely solid state color studio system we designed. We are proud of the long range investment value it has represented to many of our customers.

Figure 9 shows a device called a mixing-and-effects amplifier. This one contains some interesting characteristics. Fade and lap dissolve may be accomplished between a color and a black and white signal. A sensing device in the equipment automatically makes very important and necessary signal corrections in the process.

Color Film System

Figure 10 is the TK-27 4-vidicon color film camera system including black and white monitor, a TP-15 multiplexer and a TP-66 projector. Each of these equipments incorporate all four of the design characteristics we previously discussed. This color film system has received very wide acceptance and is in tremendous demand during the current color boom.

Similarly, the TP-66 Projector, the new color projector, has received excellent acceptance. It has many features, such as automatic cue, fast start, easy threading. All the circuits in it, of course, are solid state. It's important that a projector for color TV have "long-application time" in order that the signals be free of shutter bar and other undesirable characteristics that your engineers could describe in detail.

The TP-15 Multiplexer accomplishes the transfer of light between projectors and cameras in a very flexible manner—and is provided with local and remote control equipment.

Color TV Tape

In the tape recorder area, you will find three different machines available for your use in color TV. Figure 11 shows the TR-3 Tape Machine, a completely transistorized device, easy to colorize by addition of accessory modules, which are plugged into the space provided for them in the machine. This is an unusual machine—it's a playback machine. It is still a complete exclusive in its market. The price, of course, is comparable to the function. It is an economical way of broadcasting (or checking) either black and white or color tape. It is a standard quadruplex machine.

Figure 12 illustrates the TR-4, which is both a record and a playback TV tape machine easily convertible to color. The



FIG. 11. TR-3 TV Tape Player.



FIG. 12. TR-4 Compact TV Tape Recorder.



FIG. 13. TR-5 Mobile Tape Recorder.

TR-4 and the TR-3 both produce high quality broadcast color pictures. They are in increasingly wide use and we have noticed increased acceptance through quantity orders from multiple station groups in recent months.

Here in Figure 13 is another exclusive. An extremely compact, mobile record and playback machine — standard broadcast quadruplex. It's actually record for either black and white or color. At the present time it plays back only in black and white. It's completely transistorized and modularized, of course. It's especially designed for those recording jobs in studio and on



FIG. 14. TR-22 Deluxe TV Tape Recorder.

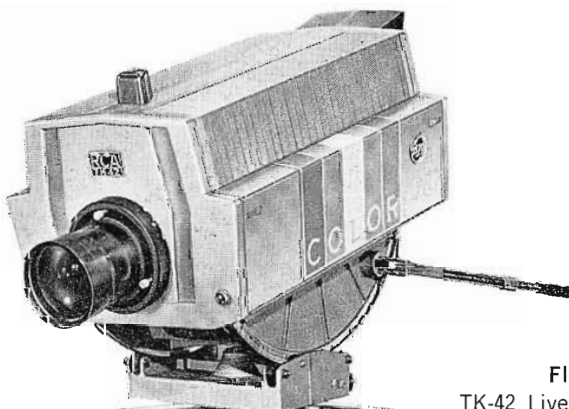

FIG. 15. TK-42 Live Color Camera.

location that require a small, easily movable instrument.

Figure 14 shows the TR-22 TV Tape Recorder, first of the new generation machines, that which set the modern pace for the industry. It is a transistorized recorder, is the most widely used single type in the market today. Those people fortunate enough to have any of these machines can make a very easy transition to color by addition of accessory modules.

Live Color Camera

Figure 15 shows the RCA TK-42, the brand new live color camera, a four tube camera, with 4½ inch I.O. luminance channel, and 3 vidicons. This camera is

the one which is going to launch the big job in this country in the live color area. We know already from the degree of acceptance that this is the one that's going to be the workhorse of the color studio.

The TK-42 is the key item in RCA's "New Look" transistorized and modularized color camera line of equipment. You will be interested to learn something of the difference between this very new 4-tube color camera and the 3-tube mentioned to you in our earlier discussion of fundamentals. In Fig. 16, we show the basic difference between the two cameras. As you can readily see, there is a certain simplicity of the circuitry in the 4-tube

approach. Also like 4-color printings, the 4-tube camera employs three primary colors—plus black, in order to get the utmost in color reproduction.

Color Transmitters

We must say something about the new transmitter lines in order to complete our story on color equipment. The RCA TTU-30, is a 30 kW UHF transmitter built primarily for extremely stable operation, for excellent handling of color signals, with provisions for remote control and even unattended operation. This is important, particularly when you think of the savings involved in

FIG. 16. New 4-tube RCA Color Camera compared to older 3-tube camera.

COMPARISON OF 3- AND 4-CHANNEL COLOR SYSTEMS

4-TUBE COLOR SYSTEM

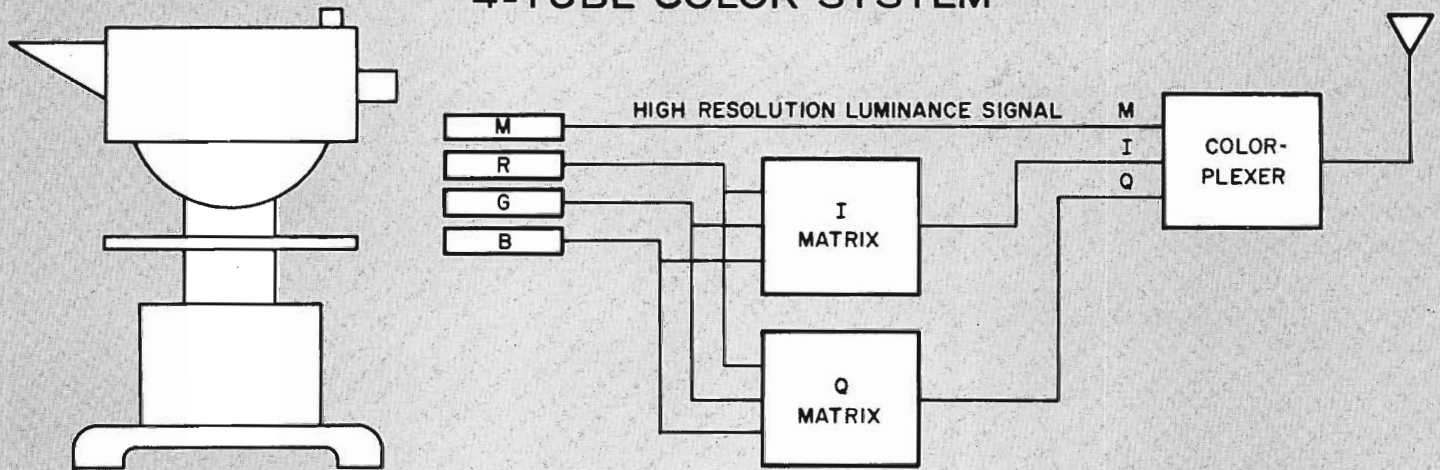

3-TUBE COLOR SYSTEM

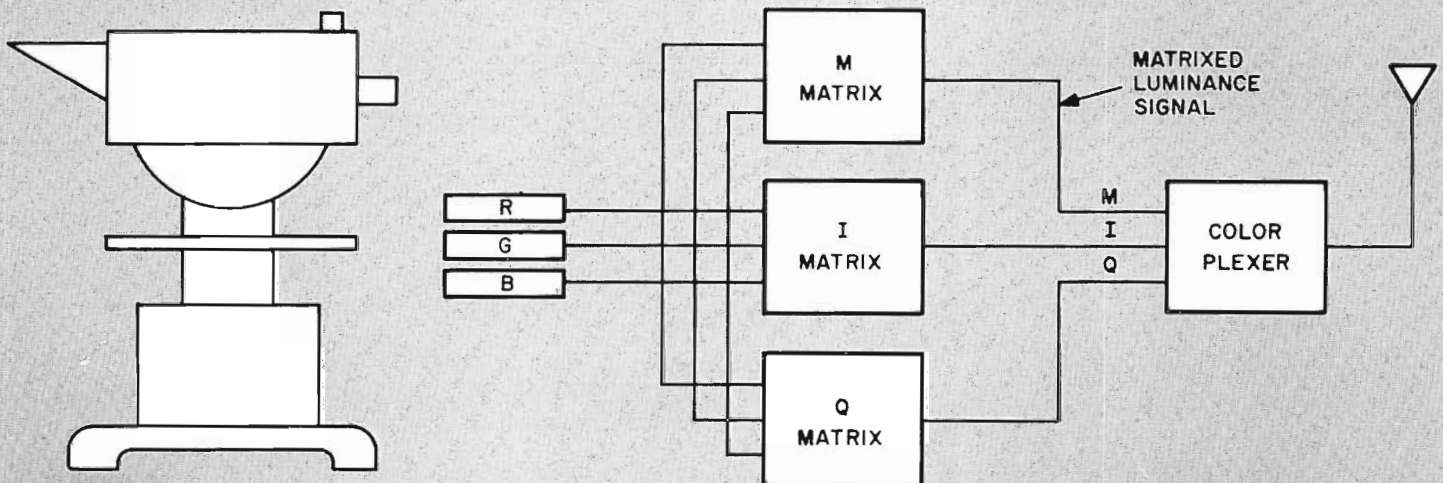

Block diagram showing how the luminance tube supplies monochrome signal simplifying the camera matrixing circuitry.

utilizing these capabilities. This transmitter is characteristic of a line that includes VHF transmitters and I am using it to illustrate a modern design for high quality, highly flexible equipment for television transmission.

We have to this point, discussed some of the major color equipments with which you will need to be familiar as we get into further discussion of color conversion methods and costs.

**PART III
TYPICAL CONVERSION SCHEME
AND COSTS**

In the third part of this discussion, which has to do with the conversion process itself, I'd like to point out that there are normally four general steps that take us all the way to color—in terms of alterations to the monochrome TV station, (See Fig. 17). First we will discuss transmitter modification; second, the color film facility; third, the color tape facility; and fourth, live color. In this discussion, I'm going to add one more step, which covers some general requirements in the studio area.

Transmitter Modification

Today, transmitter modification is an accomplished fact for most broadcasters handling network color. It may be a different matter for ETV stations. At any rate, there are selected alternatives here. Figure 18 represents in block form a monochrome transmitting plant. There is input and monitoring equipment together with a transmitter, an antenna on a tower, and transmission line. In contrast, Fig. 19 shows what this looks like when converted to color. Note, we have added a color monitor and some input equipment. The phase correction network is marked and "DA" means distribution amplifiers. There are no additions to either the transmitter proper or to the antenna. This is essentially the minimum equipment required for this part of the job.

Even a modern transmitter or one that has been up-dated and is in good working order coupled to a good quality or properly maintained antenna does not have the capability for properly handling a color signal without some correction. Limitations are not in the transmitting elements themselves, but relate to the characteristics of our single sideband transmission system and the limitation of the 6 mcs. channels allocated. Compensation is provided by the phase correcting network shown. *It is*



FIG. 17. Four general steps to color.

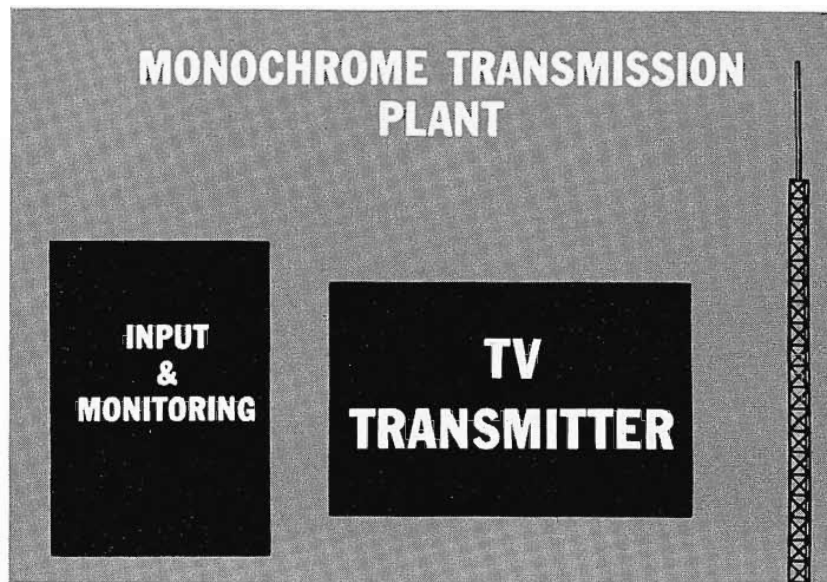

FIG. 18. Representation of monochrome transmitting plant.

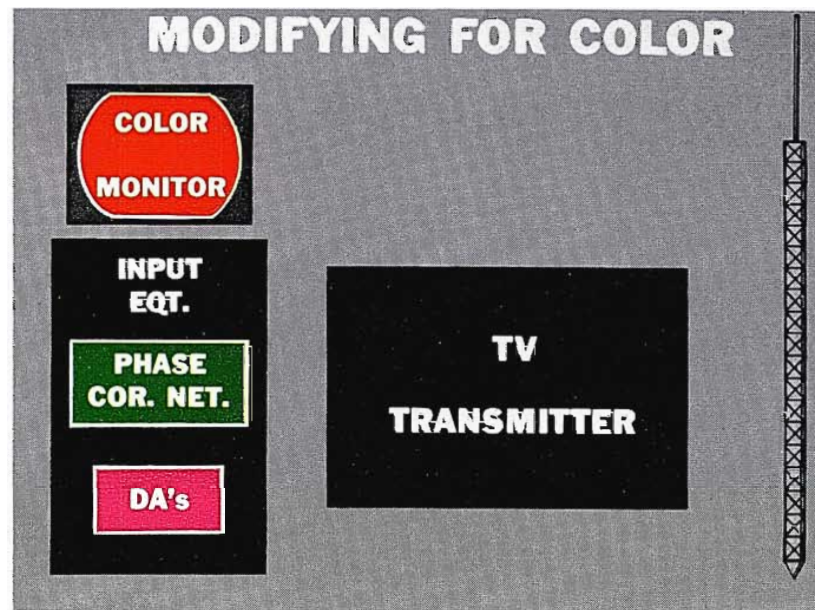

FIG. 19. Transmitting plant converted to color.

MODIFYING TRANSMITTER FOR COLOR	
Phase Correction Networks and Distribution Amplifiers	\$3,710
Color Monitor	2,450
Video Test Set	3,565
Receiver	978
Envelope Delay Set	2,830
	<u>\$13,533</u>
<i>Less Applicable ETV Discount</i>	

TABLE 1. Costs of transmitter modification.



FIG. 20. Studio equipment for medium or small market station.

MODIFYING STUDIO FOR COLOR	
Color Frequency/Burst Flag Generators	\$1,990
Distribution Amplifiers and Power Supplies	2,505
Color Stabilizing Amplifier	1,590
Color Monitor	3,560
Color Bar Generator	5,800
Test Signal Generator	3,800
Wide Band, Dual Trace Oscilloscope	2,076
Vectorscope	1,950
	<u>\$23,271</u>
<i>Less Applicable ETV Discount</i>	

TABLE 2. Costs of studio modification.

essential no matter how fine a transmitter you may have. Conversely, if the transmitter has certain inherent limitations, the phase correcting network may not adequately compensate for it.

Table 1 contains a list of equipment for modifying the transmitter for color. Also shown is the typical cost for sufficient equipment to do the job adequately. The color monitor is of a standard type. The video test set has to do with putting complex color signals through the equipment in the transmitter plant and is used with other devices such as the Vectorscope for measuring and analyzing. The receiver is a high quality design to provide a monitoring picture directly from the transmitting antenna. The envelope delay set is a sophisticated test device. It has to do with the capability of the transmitter to pass a complex wave of the color television type. The overall dollar figure is approximately correct.

I must reiterate that transmitters which appear to do a satisfactory job in black and white may be unsatisfactory for the transmission of high quality color signals. Your engineer should investigate this matter for you to determine whether or not your transmitter will pass the color proof of performance required by the FCC. If your transmitter is limited in frequency response capability or suffers from excessive differential phase or gain characteristics, you will certainly have to face either expensive modification or replacement in its entirety. The cost of so doing has not been considered here.

Studio Requirements

It is also necessary to take a careful look at the equipment you have in the studio. I'd like to give you some check points on this after showing you the nature of the equipment you might have to purchase, assuming you are a medium or small market, black and white station. Figure 20 is a block diagram of the representative studio layout.

In Table 2, we have at the top the equipment that deals with signal handling capabilities, while the group at the bottom is test equipment. All are average cost figures. The color frequency burst flag generator has to do with the generation of the color picture in the studio. New distribution amplifiers and power supplies are shown, since almost every station has some inadequate equipment that must be replaced. The stabilizing amplifier is a special one required for color. Many black and white stabilizing amplifiers will not do the job, and so on down the list.

Included is a color bar generator which originates a series of vertical color bars across the picture tube. It is an important device since its signal is used to evaluate technical performance of all the station equipment through which it is passed. The test signal generator puts out a complex signal, to perform many important functions. A wideband dual-trace oscilloscope is also included. A very complete set of test equipment is listed for the studio and inclusion of all this equipment in your station will make it possible for your engineering group to do the best possible technical job.

Film System Requirements

Typical film systems appear in block form in Fig. 21. On the left is a monochrome film system. This is based on RCA equipment of older vintage: TP-16 16mm Film Projector, TP-3 Slide Projector, TK-21 Camera and TP-11 Multiplexer. Any engineer will recognize that combination as having been very popular. On the right, you have the color counterpart: Type TK-27 Color Film Camera, TP-15 Multiplexer, two TP-66 Film Projectors, and TP-7 Slide Projector.

At this point, we will give you an estimate of the costs in this color grouping. This is where we first get into what you might term "big money" in the transition to color. The cost figures shown in Table 3 are for a completely new color system, whereas your cost could be less—depending upon whether elements of your present system are convertible to color operation. This price structure covers the very best in color film equipment, however, you will find that there is not too much variation between manufacturers for equipment of similar quality. To my knowledge, there is no availability in the current market of really low-priced color film equipment that is adequate to do a broadcast job properly. If you require a good quality film system, you are talking about something along the line of these prices.

Of course, sometimes economies can be developed. It may be that you don't need two film projectors, for instance. In the case of the rest of the equipment list, it's almost essential you go to color film along the lines that the major stations do.

Now you may come up with questions relating to the convertibility of your own equipment. As I suggested with relation to your transmitter plant, it is necessary for your engineer to check the elements in your system to see whether any are

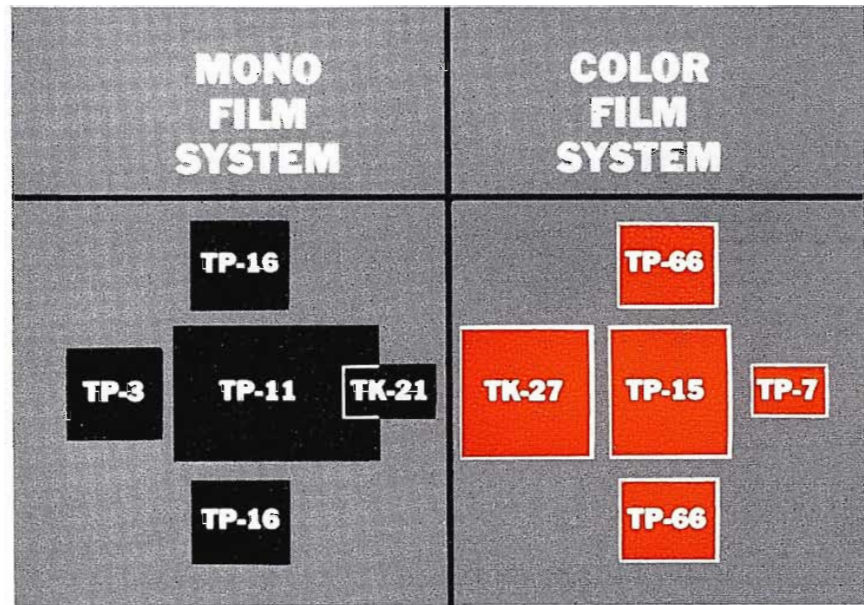

FIG. 21. Typical film systems compared.

usable for color and some of you may be fortunate enough in that respect. Projectors frequently are not usable. This is the most common reason why older projectors frequently are not usable: The light output may be insufficient to accomplish the transitions through the multiplexer or it may not be sufficiently stable to produce the superior color picture you will require of your new system.

There are also complexities in the multiplexer. You notice that we have a multiplexer listed as the second item. Not all multiplexers are capable of transmitting the light efficiently from the source to the color camera. Also, multiplexers frequently are not color corrected and there may be aberrations in the transmission of light. Again, a careful evaluation is desirable by your engineers.

COLOR FILM EQUIPMENT	
Color Film Camera	\$54,495
Multiplexer and Remote Control	6,500
Two 16MM Film Projectors	24,570
Slide Projector	3,750
Projector Light Controls	3,450
Console	525
	<hr/>
	\$93,290
Less Applicable ETV Discount	

TABLE 3. Color film equipment costs.

TV Tape Requirements

Now, if you're fortunate enough to have an RCA TR-4 Tape Recorder, the compact one, which is easily convertible for color, you will be able to go from the monochrome condition illustrated at the left in Fig. 22 to the condition on the right (full color recording and playback) simply by purchasing and plugging in the required accessory (CATC) color modules.

Table 4 shows the estimated costs of conversion, but it will be gratifying to some of you to be able to modify your machine (which costs approximately \$35,000 to purchase) by installation of the modules with no loss of initial investment. These figures remind us to say a bit about color tape recorders. Many of you no doubt have tape recorders. The matter of conversion of a tape recorder is not a simple matter. It depends a good deal on the type, the age, and the method that has to be used for conversion.

To the best of our knowledge to the present time, only standard broadcast quadruplex tape recorders can be used for color. No one has yet demonstrated or made available, as far as we know, a satisfactory slant track recorder operating in a color mode. Perhaps some day this will be corrected, but there are many complications. On the other hand, any quadruplex recorder built by RCA, or by another major supplier can be converted to color at "some" price. These prices range anywhere between \$9,500 and \$27,000.

Should you have a tape recorder of older vintage, it may be that the total value

of the machine, at least in the market, isn't over \$12,000 or \$15,000 today, and it would give you second thoughts if you had to spend \$27,000 to convert that particular machine to color. It would be very wise to decide whether a new modern machine might be a better investment than an expensive modification of an older machine with inherent technical limitations.

Live Color Cameras

The final consideration is the addition of live color to the station. Figure 23 demonstrates the way live color is most often added to medium and small market stations—by adding live camera equipment to the existing facility.

The studios are usually of such proportions that they can take the requirement of the new color camera, and almost always there is room in the control room for the monitor console and associated gear that goes with it. In commercial stations, it has become common to provide new studios coincident with major color implementation, but in most cases, you will find that the initial start in color was made with a single live color camera in an existing black and white studio.

Now, here again we are in the big money area. Table 5 reveals that the live color camera is in the \$70,000 bracket, which is the cost for a minimum system; however, it is a complete color camera system. Naturally, there is the advantage of the applicable ETV discount to educational broadcasters.

We should point out at this time that once in a while, a broadcaster has elected to procure the live color camera first,

rather than proceed in the stages we have suggested. If that were done, you would have to add to this cost whatever conversion was necessary in the transmitter plant as described before, plus whatever conversion was necessary in the studio plant in order to derive a total figure.

At this time, we present in Table 6 the figure for the overall equipment costs for total conversion to color. Here is the addition of everything we mentioned. In the color tape area, we took the liberty of giving you every monetary advantage, whereas, if your investment involved a brand new tape machine, we might have a \$60,000 to \$70,000 figure in that area.

Of course, there are many times when economies are possible in the process of color conversion. Our figure provides only a *single* live color camera, implying some inevitable limitation in studio flexibility. However, the figures shown do give you, with reasonable accuracy, the nature of equipment lists and the dollar value of contracts which are generally written for color conversion purposes in both commercial and educational markets today.

PART IV

COMMENTS FROM COLOR STATION MANAGERS

As manufacturers, we are not really experts either in operating color television facilities or in accomplishing conversion of a monochrome facility (while continuing to operate)—but we have many friends in the business who are experts. I have asked some of these experienced people questions in order to procure guidance for you. I have comments from four experi-



FIG. 22. Modifying tape equipment for color.

COLOR TAPE RECORDING EQUIPMENT	
Automatic Timing Control	\$7,900
Color Automatic Timing Control	9,950
	<hr/>
	\$17,850
<i>Less Applicable ETV Discount</i>	

TABLE 4. Color tape modification costs.

enced managers with regard to operating costs, sets, scenery and drapes, lighting, program and production people and engineering personnel. I will give you verbatim what these people said in response to my questions. This should enable you to make some valuable and I hope pertinent deductions.

Operating Costs

With regard to operating costs, we have the impression from talking to four station people that operating costs for equipment were generally secondary and frequently had not even been analyzed. The four, all experienced in the transition to color, all started with a single live color camera and all made the complete transitions with regard to the other facilities which we discussed earlier.

We are not including program costs in this discussion as they are beyond the scope of our subject. The first manager said, "The slight increase in operating costs for color cameras were those related to warm-up and maintenance time and required no added personnel." This particular manager talked about a warm-up and maintenance period that added about one hour per day or for each scheduled period of usage.

The second gentleman said, "The present black and white image orthicon cost per camera should be multiplied by two or three for a color camera. This seems to be a rather basic figure, two or three times the cost for a single I.O. Figure what your cost of I.O.'s is, because that in itself is a measure of how careful you are, what you are able to do to economize, what your engineering department is able to do—multiplied by two or three."

Here's the third answer, "We estimate image orthicon costs for a color camera at three times that for a single I.O. camera." Here you have the predominance of the cost of the image orthicons primarily as being a major item in operating costs. (Note, of course, that this refers to the older type color camera, Type TK-41, which uses three I.O. tubes whereas today's camera, the TK-42, uses low cost vidicon type tubes.)

Here's one that mentions power cost, "We encountered some added power cost but it was related to added lighting in the studio." We do not claim that this is conclusive, but when you ask an experienced manager what his costs are in the operating area, you get that kind of an answer, and these are all very capable, experienced people.

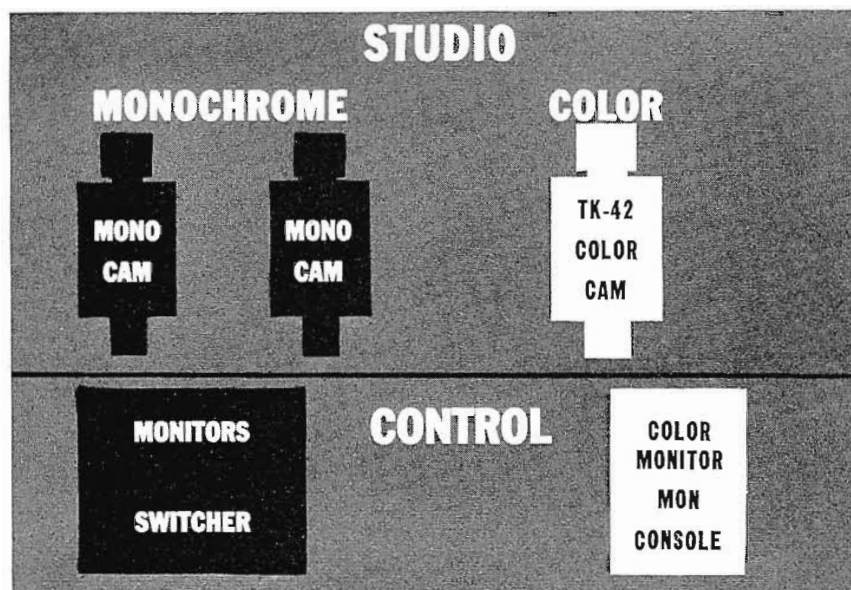

FIG. 23. Adding live color to medium and small market stations.

<u>LIVE COLOR CAMERA EQUIPMENT</u>	
Color Camera	\$70,920
Monitoring Console	3,172
Color Monitor	2,450
	<u>\$76,542</u>
<i>Less Applicable ETV Discount</i>	

TABLE 5. Color camera equipment costs.

<u>TOTAL COLOR EQUIPMENT COSTS</u>	
Trans. Mod.	\$13,533
Studio Mod.	23,271
Color Film	93,290
Color Tape	17,850
Live Color	<u>76,542</u>
	<u>\$224,486</u>
<i>Less Applicable ETV Discount</i>	

TABLE 6. Total equipment and modification costs.

Production Problems

Now with regard to sets, flats and drapes. One manager stated, "We used what we had and made very few changes. We produced some experimental flats, did not find it necessary to replace drapes that were already in the studio." Another reported, "We learned much by experience, including the necessity for avoiding large background areas in saturated colors, by performing much color experimentation in the studio. We now have two commercial staff artists who assist with props." The third replied, "We experimented extensively with colors in the studio with the assistance of our staff artists." The fourth stated, "Our shows are not Hollywood style and our backgrounds are frequently replaced. We use rear screen projection equipment with slides for low key backgrounds and abstracts. It's important that someone on the staff have good color sense." That, by the way, was from one of the most experienced operations in the country—one eminently successful with live color origination.

Color Lighting

Here are some ideas with regard to lighting. One reports that no additional space was available originally for additional lighting equipment. An effort was made to use the existing lighting, with more of it trained on the subject area. This was not satisfactory, and was a factor in building a new facility capable of 300 foot candles over the entire studio area. This station did operate for a period of a year or more under the original condition.

Another said with regard to lighting that no original expenditures for additional lighting fixtures were made at the outset of conversion to color: however, when new studios were built, additional lighting was added. They did operate though in the

interim as best they could with the monochrome lighting.

Another found it necessary to increase black and white lighting by a factor of three in foot candles. They acted upon the advice of experts from the network who studied their system. This points up a source of information that has been helpful in a fair number of instances.

Finally this: "Black and white illumination of 75-100 foot candles was increased to 250-300. Added air-conditioning was required with this transition. Provision for special spotlighting was added. Freedom for lighting interpretation for our production staff was provided in this way."

Program and Production Personnel

In each case, the station making the transition used at least one live camera. Number one reported, "Color production required no increase in program production personnel. Color production required no increase in force. Part of the price of our pioneering involved learning to work with color programming virtually without reference to other TV operations."

Number two reported, "For single live camera programming, there were no additions to the production staff. They took in stride the job of doing monochrome as well as color work in the same studio." Thus, it was a simple addition without change of people.

Number three stated, "Our production people experimented extensively with colors in the studio. Our staff artists assisted with these tests. Our people learned by doing rather than by following prescribed suggestions from outside."

Number four said, "Our original group proved capable of handling our original color studio with no increase in force. Later increases related to additional cam-

era equipment and an extension of our color program schedule."

Engineering Personnel

Here is what the experienced stations say: "Our engineering people picked up the complexities of color and operated to the complete satisfaction of management." Number two, "The color opportunity raised morale and offered a welcome challenge to our engineers. Full use was made of seminars." Number three, "Color presented no problem other than re-scheduling by the chief engineer. Our involvement in automation required that two of our best men be freed from this operation for special training and assignment to maintenance and technical work, pointing up, of course, an increase in the technical requirements with respect to the complexities of color." Number four, "Color provided a challenge to our best engineering people and they reacted with enthusiasm."

I couldn't find a better point at which to bring this discussion to an end and I was very pleased, of course, to get such helpful replies from these good friends of ours. In this overall discussion, we've seen that color implementation will provide an increasingly essential tool to the progressive ETV station. We've seen that the time has come for a study of ETV plant facilities relating to usability for color programming and that a comprehensive plan for providing the necessary equipment should be formulated immediately. We've seen that a capable existing staff of an ETV station is likely to be enthusiastic about an entrance into color and will require augmenting only in proportion to expansion in plant facilities and program format.

In conclusion, I trust that before too long some of you will be able to boast of an operation in color that performs in a truly professional manner.

COLOR TV TAPE PLAYER

Design Innovations Make the TR-3 An Easy,
Low-Cost Way to Color

by M. C. KIRKAS

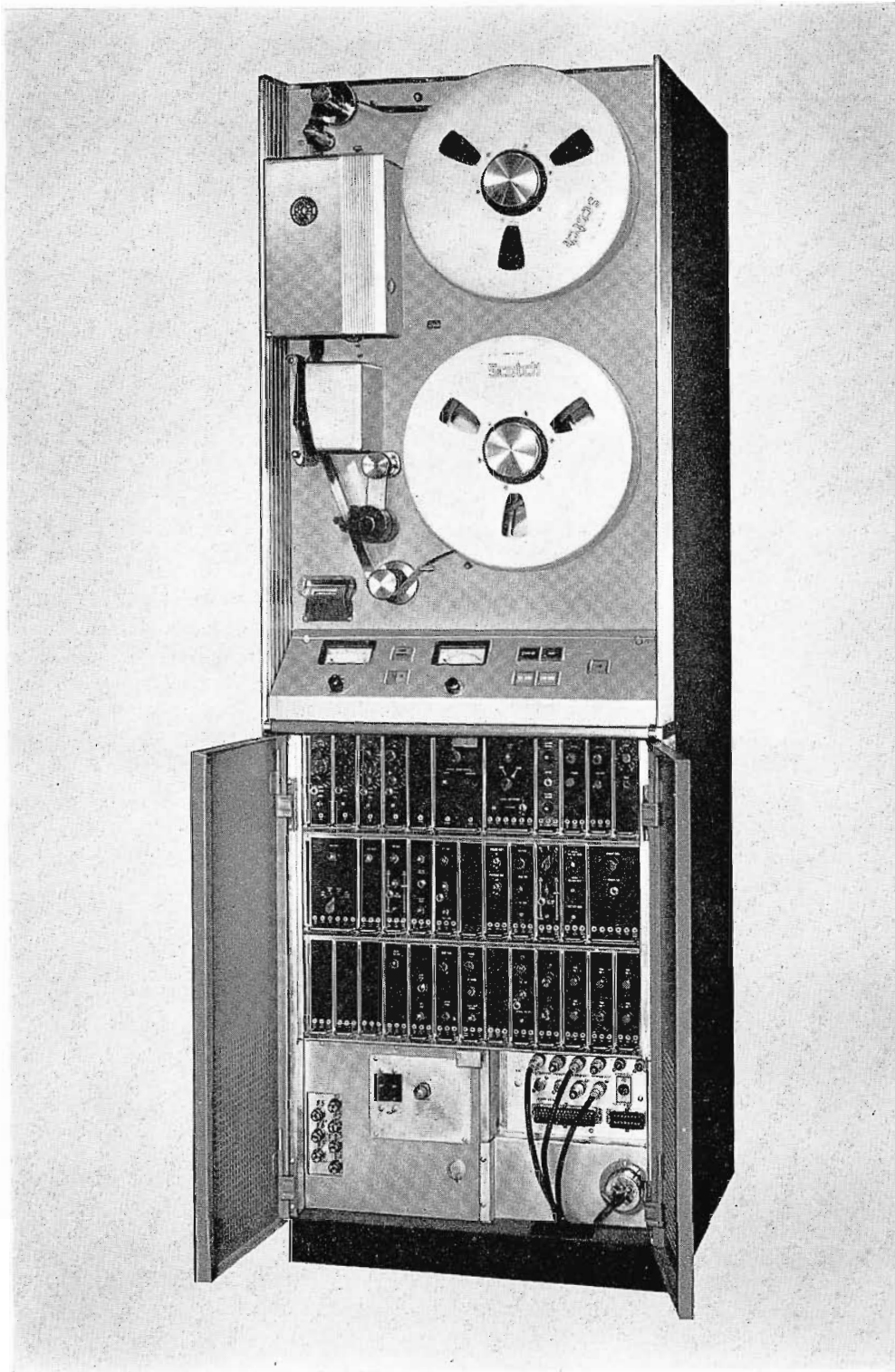

A unique, completely transistorized "New Look" equipment, the TR-3, provides a convenient and economical facility for playback of video tapes. The basic TR-3 is a player only. Thus, it provides an additional TV program source in a very small space with a minimum investment. It may be used for monochrome only or by adding the accessory modules, may be used both for monochrome and color. It may be further expanded into a complete record and play machine by adding a monitor-record rack.

Complete Compatibility

All TV tapes made to broadcast standards on quadruplex recorders can be played on the TR-3, so the player serves broadcasters as well as users of closed circuit TV. Built-in circuits permit a choice of either $7\frac{1}{2}$ or 15 inches per second tape speed. Playback time for the TR-3 at 15 IPS is 90 minutes, while total time at the tape saving speed of $7\frac{1}{2}$ is 180 minutes.

Matches "New Look" Recorders

Design of the TR-3 follows the high professional standards achieved in the RCA matched TR-22, TR-4 and TR-5 series of recorders. The TR-3 incorporates much of the advanced circuitry that is in these machines, including the transistorization, modularization and standardization so essential to low power consumption, high reliability and reduced maintenance.

The same attractive and completely functional styling is used in the TR-3. Controls are placed on a handy sloping panel at fingertip height. Tape reels are at convenient chest height where they are easily

FIG. 1. TR-3 TV Tape Player.

slid on and off. The TR-3 stands 66 inches high and takes less than four square feet of floor space. It can be readily moved on its built-in casters.

The TR-3 rounds out a full complement of units designed to provide the tape user with the right machine for his application.

Supplements Present Tape Facilities

The TR-3 is a versatile supplement to present broadcast and closed circuit TV taping facilities by relieving heavily scheduled recording equipment at relatively low cost. Broadcasters have found already that they can increase their program flexibility by combining the player with standard record/playback units such as the TR-4 and TR-5. For example, before introduction of the TR-3, playing of tapes had to be scheduled for times when the recorder/player was not being used for recording, since it could perform only one function at a time; however, the TR-3 can be used to air tapes, or for client screening of commercials and programs while TR-4 or other recorders are busy taping and editing, thus making most efficient use of tape facilities.

A Low-Cost Facility

With appropriate accessories, the TR-3 provides playback of color tapes in their original full fidelity. The accessory Color and Monochrome ATC modules are transistorized plug-in units containing automatic circuits that precisely apply time base correction to the tape playback signal as required for color. There are built-in provisions for accommodating the accessory color modules, which plug into the prescribed spaces.

Excellent color and monochrome pictures are obtained by the TR-3 while featuring the economy of play only operation. It is an excellent way to "get into color." Color tapes produced by stations or syndicated color tapes may be aired on the TR-3. Later, when the station adds film and live color, this TR-3 will become part of the overall system.

Built-in Pixlock

The TR-3 incorporates the extremely stable Pixlock synchronizing and timing circuits that permit supers, lap dissolves and special effects between tape and other

TV signals. Pixlock accurately synchronizes vertical sync and horizontal sync pulses derived from the tape with the pulses from the local sync generator.

Basic Playback Design

Since the signal on video tape consists of a frequency modulated RF carrier, the video tape player necessarily includes FM components associated with the video circuitry. In addition, there are the servo, audio and control circuits. The electronics of the TR-3 player are shown in the block diagram of Fig. 2, and can be divided into four systems:

1. Video and FM
2. Headwheel and Capstan Servos
3. Audio
4. Control

Briefly, the video and FM system is concerned with transforming the picture signal recorded on tape to a standard, one-volt video signal for broadcast or screening purposes. The headwheel and capstan servos control the precise speed and timing necessary in the rotation of the video heads

FIG. 2. TR-3 Functional Diagram.

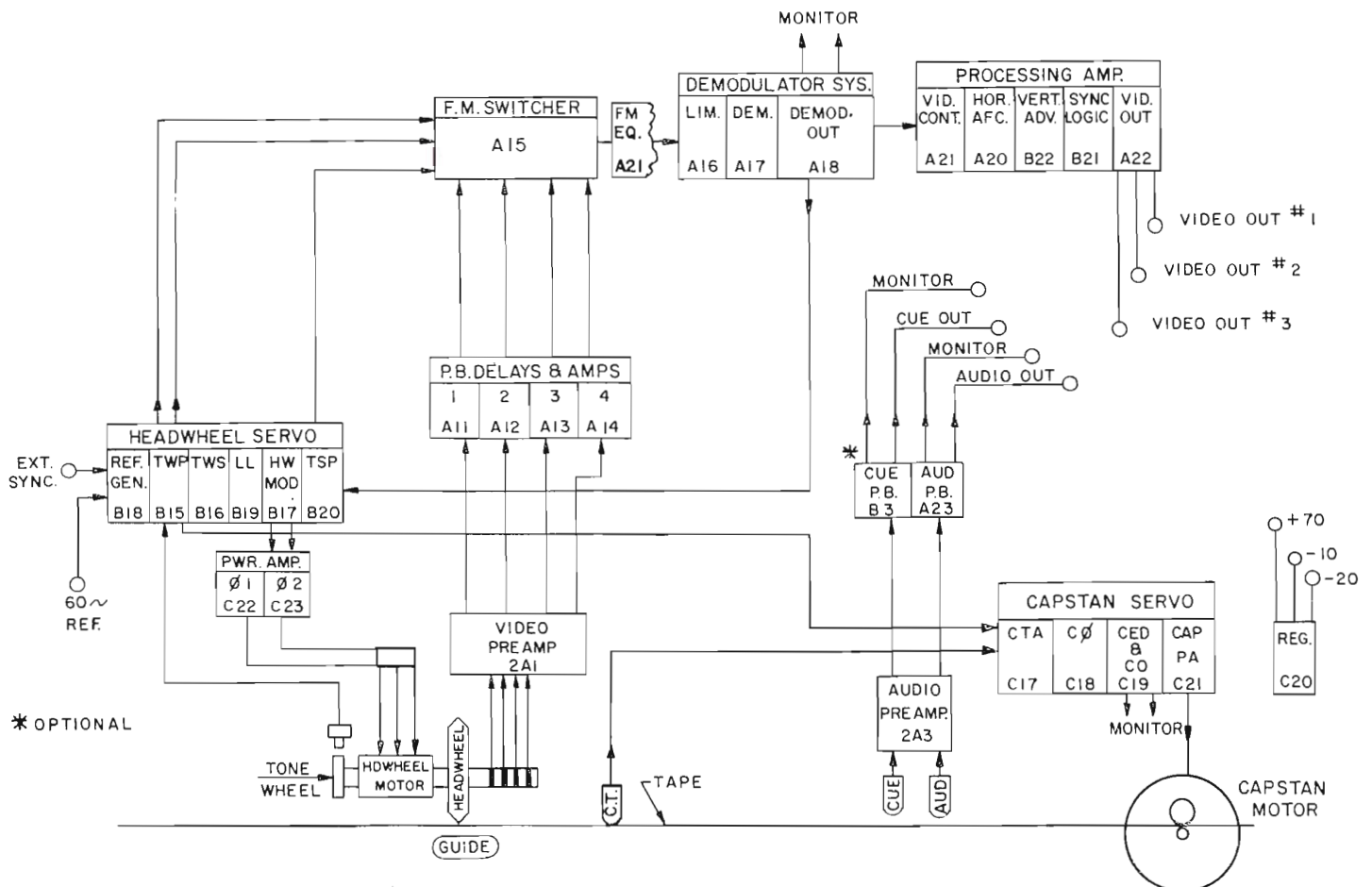

and movement of tape for distortion-free pictures. The audio system amplifies and reproduces program sound and cue information recorded on the video tape. The control system performs the memory, logic, and the simple mechanical and electrical switching encountered when changing the mode of player operation.

Video and FM Systems

The video system describes the signal path from the transverse video tracks on the tape to the output of the player. The system consists of three functional groups: The FM sub-system comprising the playback amplifiers, FM switcher and FM equalizer; the demodulator; and the processing amplifier.

In the playback amplifiers of the FM sub-system, signals from the four video heads are amplified in separate channels, corrected for quadrature error, equalized, and then assembled into a continuous signal by an electronic switcher.

The equalizer stage is adjusted by a front panel control and compensates for variations in frequency response of the individual video heads. Each FM amplifier channel has its own gain control, adjustable equalizer, and adjustable delay amplifier for correction of head quadrature to match that on the tape.

FM Switcher Operation

The equalized and quadrature corrected signals from the four video heads are then fed into the FM switcher. This is a 4 x 1 (4 input x 1 output) unit containing two matrixing circuits which form a 4 x 2 and a 2 x 1 combining network (See Fig. 4). The 4 x 2 network selects the four outputs in such a way that heads one and three and two and four appear together. In the 2 x 1 matrix, heads are then mixed (switched) so that the signal contains heads one through four in their respective sequence. Matrixing is accomplished by 960 cycle control pulses for the 4 x 2 switcher and 480 cycle pulses for the 2 x 1 switcher. These pulses are derived from the tone wheel and tape sync processor modules. There is an overlap of about three TV lines between the end of each track and the start of the next track. The overlap is eliminated by switching during the first horizontal sync period in the overlap interval.

Signal Equalizing

Output of the 4 x 1 switcher is next fed to a portion of the Video/FM Control module (see "FM EQ" in block diagram) where the FM signal is amplified and the

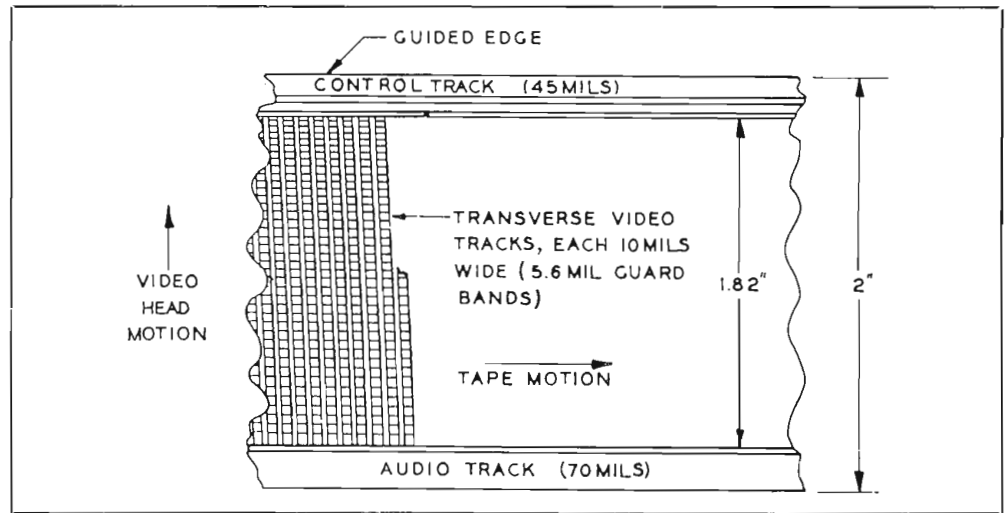

FIG. 3. Illustration of recorded video, audio and control tracks.

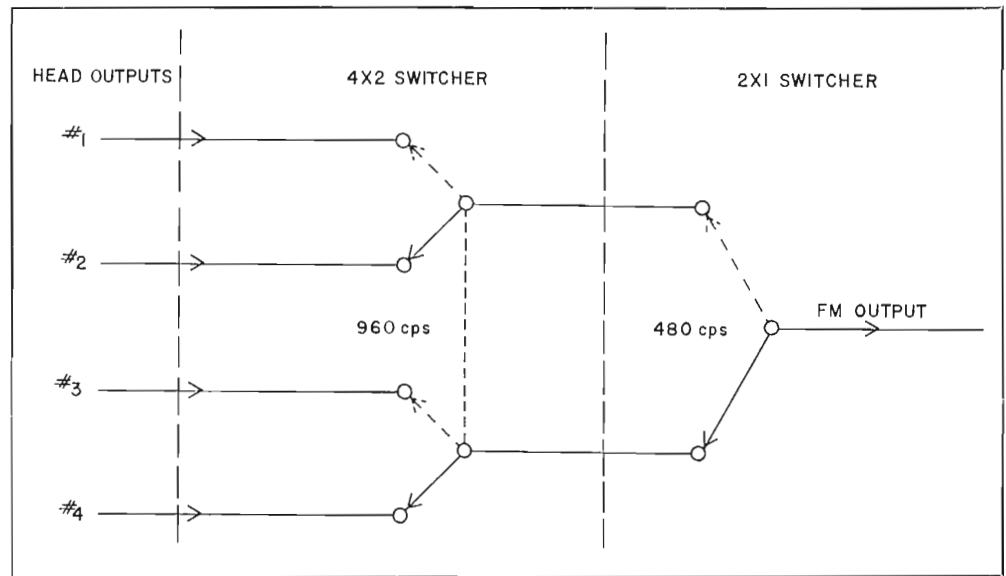

FIG. 4. Simplified schematic of FM switcher module.

frequency response of the overall signal is shaped by an FM equalizing network. The equalizing control is a variable potentiometer that permits adjusting the frequency response to compensate for variations between video head assemblies. The circuit is so designed that normally a setting of 90 degrees from counterclockwise is all the adjustment required for playback of a standard recording.

Beside its main output, the Video/FM Control module provides an FM output for monitoring purposes. The signal is amplified and detected and then fed to the control track meter which indicates the relative position of the control track with respect to the optimum phasing of the control track signal. Adjustment of the control track phasing control corrects the signal from the capstan error detector network.

High Degree of Limiting

The main output from the FM equalizer network goes to the first of the demodulator group, the limiter, through which the signal is passed in push pull and is processed to achieve an overall limiting characteristic of 55 db or more. This is an amount sufficient to allow the RF signal level in the demodulator to be 55 db below nominal before the video signal is affected by a 10 per cent reduction in level. One of the two outputs from this module is for RF copy purposes. This permits operating the TR-3 as the master playback machine for making RF copies of pre-recorded tapes on a slave recording machine. The second output is fed to the demodulator.

Bridge Diode Demodulator

In the demodulator module, the FM signal is passed through a delay line giving it a certain cutoff frequency configuration.

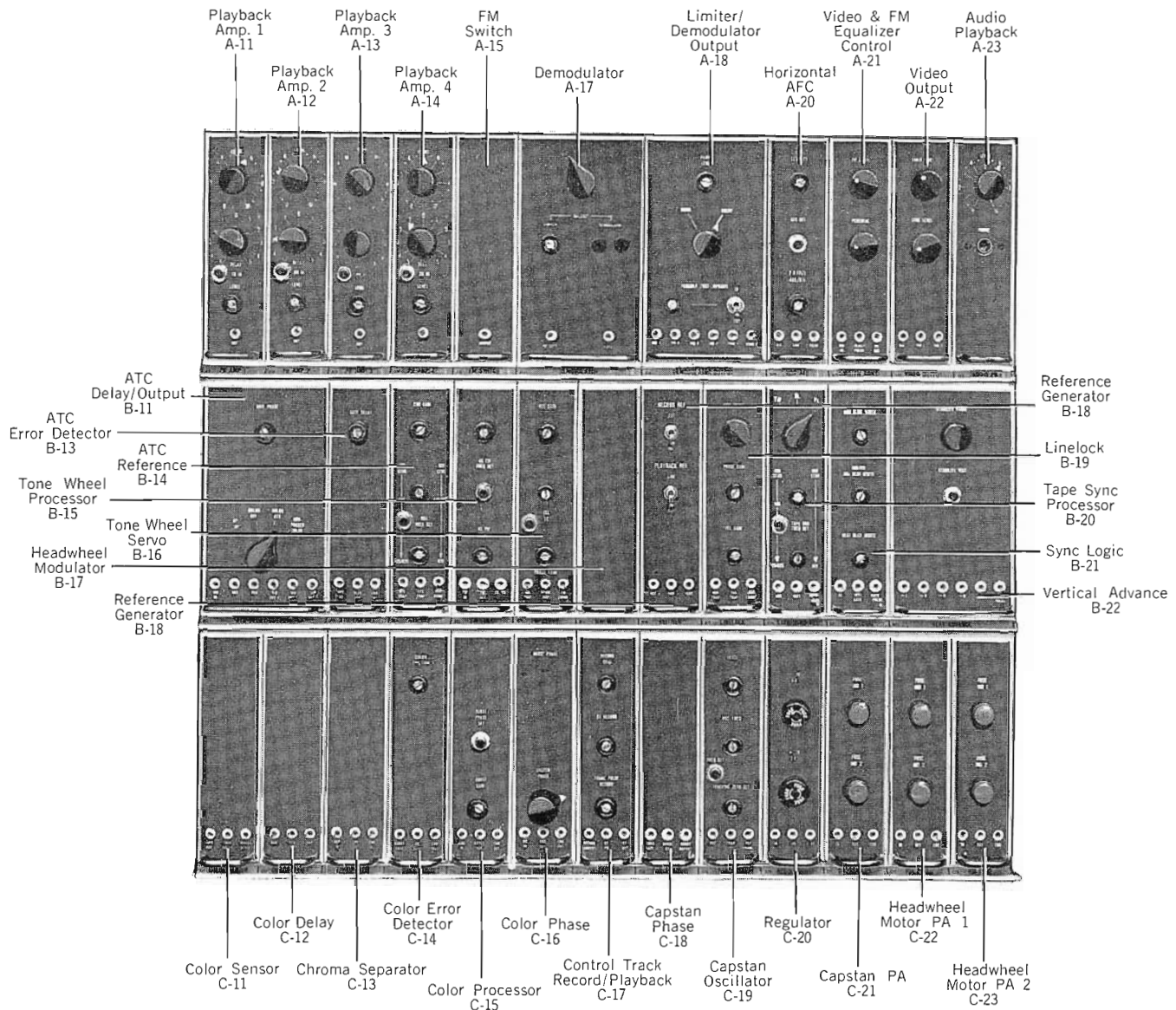

FIG. 5. Transistor plug in modules of TR-3 with optional color accessories installed.

From the delay line, the signal is amplified and compared with a signal from a fixed frequency oscillator by means of a diode demodulator network which removes the carrier frequency leaving the video signal. The video signal is then passed through a 4.5 mc filter (for monochrome standards) to the demodulator output module.

This module contains among other stages a post-emphasis network and feedback amplifiers to stabilize the signal. After traversing these circuits, the signal is passed through several emitter followers and then divided into two paths. One path has a fixed gain and its output feeds a monitor and a sync separator within the module; the other path is to the video control module where a variable gain control allows the operator to adjust the output of the machine. The output of the

variable gain system is used to supply video to both the processing amplifier and the optional ATC circuits.

The video signal to the sync separator is fed through a filter eliminating the higher frequencies. It is then amplified, clamped, and sync is separated. The separated sync is "cleaned up", stabilized, and gated so that undesirable and random pulses are eliminated. This renovated tape sync signal is then used for servo, processing amplifier and automatic timing corrector reference purposes.

Signal Processing

The composite video signal recovered in the demodulator may contain noise and other spurious elements, and it is possible that the sync-to-video ratio may be incorrect. To correct these problems, composite blanking and horizontal sync must be regenerated, and the vertical (9H sync inter-

val) reprocessed. Then, by combining the new horizontal sync, composite blanking and the reprocessed vertical sync, new and desirable sync will be formed.

This signal regeneration is accomplished in the Processing Amplifier which employs five modules: Video control; horizontal AFC; vertical advance; sync logic; and video output. The demodulator output is fed to the Video/FM Control module where operator gain control is provided. There also, the signal passes through a unity gain, variable amplifier which assures unity gain through the processing amplifier. It then passes through a stabilizing feedback amplifier stage to the video clamp which clamps on the back porch between sync and video. The clamp pulses are formed from the composite sync signal regenerated by the sync logic module and timed by the trailing edge of the sync pulses.

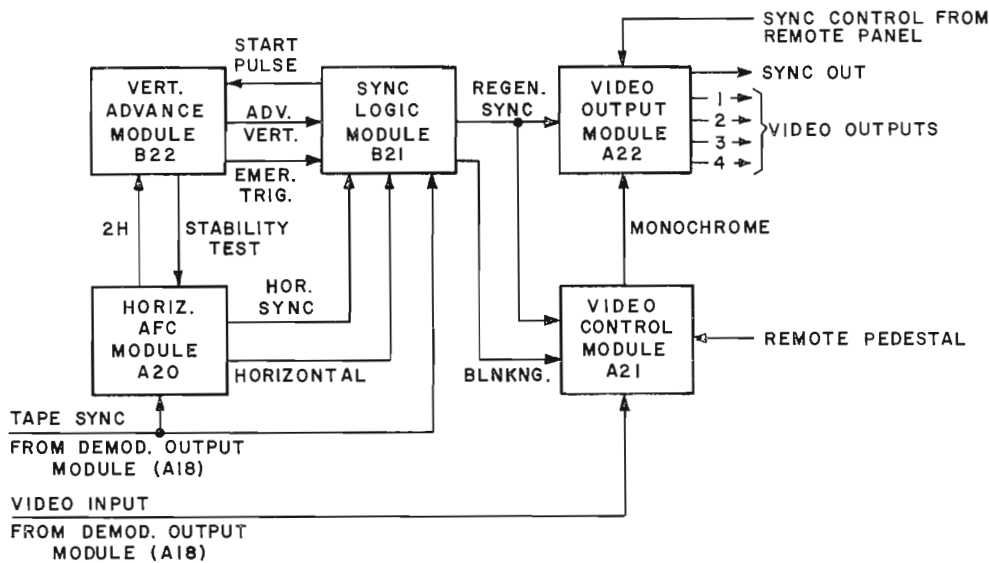

FIG. 6. Simplified block diagram of processing amplifier.

The video signal then passes to the video output module. In this module, old sync and blanking are eliminated by a black clipper. At this point chroma information is also added. The output is four sending-end terminated, 75-ohm output lines, three of which are system outputs and one is a monitoring output. One of the system outputs is switchable for composite or non-composite output.

Regeneration of Blanking and Sync

Tape sync, which is separated from the tape signal in the demodulator output module is sent to another module in the processing group, the horizontal AFC module. Here the sync is used to control the frequency and phase of a multi-vibrator. This, in combination with other circuits in the module, generates a new horizontal sync, and also provides a pulse used in the sync logic module to regenerate horizontal blanking. This same phase-controlled multivibrator sends pulses to the vertical advance module where special circuitry counts out the number of pulses in the field to determine very accurately the position for the regenerated vertical blanking.

The various outputs of the horizontal AFC module and the vertical advance module are fed to the sync logic module which has several functions. First, it generates horizontal and vertical blanking, then combines them into composite blanking. Second, it receives tape sync and regenerated horizontal sync and combines them into composite regenerated sync (using only the vertical interval from tape sync). Third, it generates a start pulse, which phases the counting of the vertical advance circuitry.

The regenerated blanking is fed to the video control module where it is inserted in the tape signal; the regenerated sync is fed to the video output module where it is added to the non-composite video signal to form a composite video output.

Thus, the processing groups output is a signal with proper set-up, regenerated sync and noise-free blanking interval.

Headwheel and Capstan Servo Systems

Precise timing is a major requirement in TV tape recording and playback. Even small timing errors cause picture distortion, flutter, and loss of synchronization in the reproduced picture.

Basically, these errors are minimized by a method of timing control called "tone-wheel lock." This is the simplest of operating modes and it uses closed loop headwheel and capstan servo systems that compare a tonewheel signal with the TV field rate to closely lock the headwheel and capstan motor rotations for proper headwheel speed and uniform tape movement. The 240 cycle tonewheel signal is recorded on the tape control track during the video recording process providing an accurate record of the motion of the recording heads. When the tape is played back, the signal is picked up by the control head, counted down to 30 cycles, and compared with a 30-cycle frame pulse made from incoming sync. The difference is an error voltage that corrects capstan speed.

Tone wheel lock is satisfactory for most routine TV tape operations, but the picture is not framed vertically in this mode, which means that for roll-free switching between tape and other TV program sources, or for insertion of special effects, more precise servo control must be used.

Switchable Timing Control

In the TR-3 TV player, a selector switch permits a choice of three successively tighter degrees of servo control: Tonewheel Lock, Switchlock and Pixlock. All three are built into the TR-3; the third of these servo modes, pixlock, utilizes a "Line-lock" plug-in module.

Switchlock

Switchlock, a standard feature of the

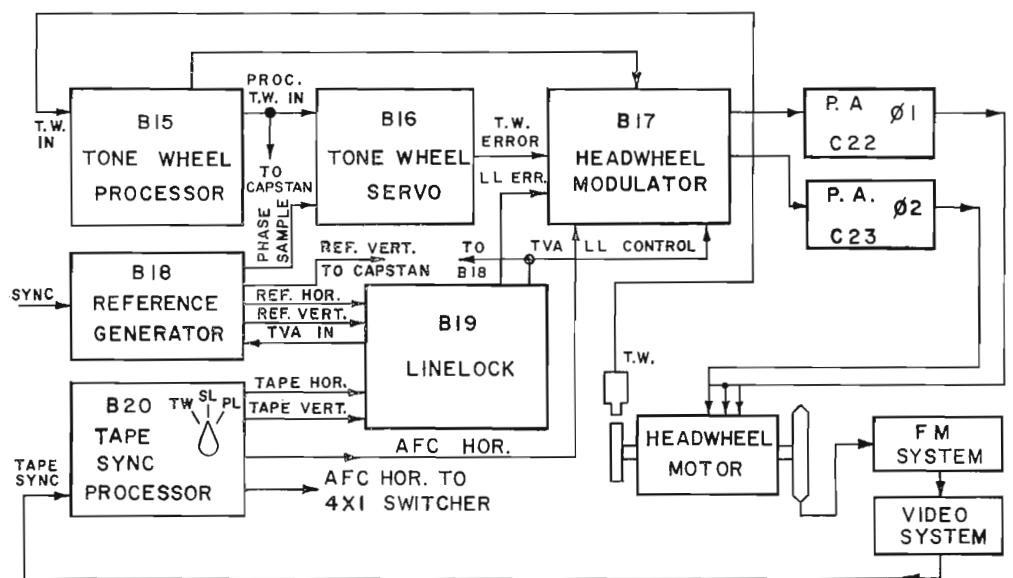

FIG. 7. Diagram of headwheel servo.

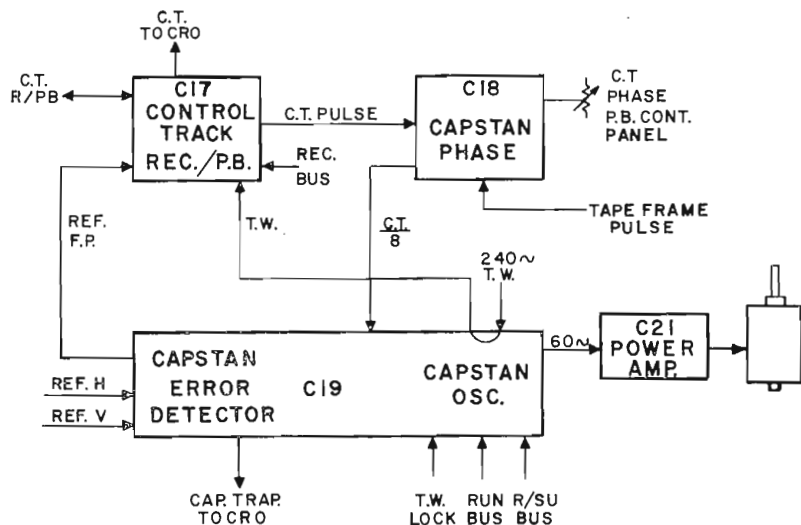

FIG. 8. Diagram of capstan servo.

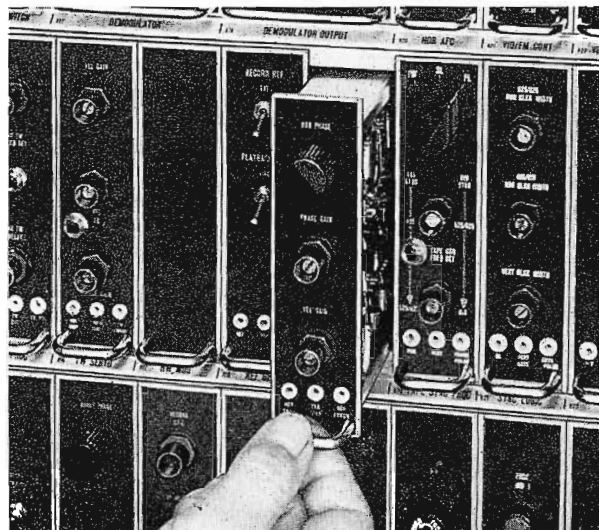

FIG. 9. Pixlock plug in module.

TR-3 TV player, offers the advantage of virtually roll-free switches from tape to other TV sources or vice versa. To obtain switchlock operation, it is merely necessary for the operator to set the mode selector switch to the switchlock position. This can be done when it is determined that head No. 1 is playing back vertical sync.

This in effect moves the switch at the bottom of the diagram Fig. 7 to the "switchlock" position, connecting the 30-cycle frame pulse from the tape sync processor to the binary counters. This causes the counters to reset (re-phase) and produce an output square wave pulse timed close to the tape frame pulse. When this pulse differs from the capstan trapezoid in the error detector, and AC error voltage is generated which shifts the capstan motor drive frequency, thereby accelerating or decelerating the tape to correctly phase the two signals in the error detector. This results in phasing together the tape frame pulse and the local frame pulse producing the switchlock mode of operation.

Pixlock

When the servo control switch is in the "pixlock" mode, the operator can superimpose live and tape sources, and also use wipes, dissolves and other special effects. Pixlock, an additional control in the head-wheel servo, provides the greatest flexibility to the tape user in that his tape follows directly the sync generated at the users location. Mode error corrections for pixlock occur on a line-to-line basis, permitting the TR-3 to be used much the same as cameras in switching scenes and special effects.

Audio System

The audio signal picked up from the tape by the audio head is fed to an audio pre-amplifier where it is amplified to a level sufficient for transmission to the audio playback amplifier. The audio signal is then further amplified, filtered to remove the 87.5 KC carrier, and fed into a 600/150 ohm balanced line. The full fidelity audio system consists of two modules, the audio preamp and the audio playback amplifier. The high quality audio head is surrounded by a hinged cover which in addition to the protection it offers, shields the head,

further increasing an excellent signal-to-noise figure.

Control System

The control system is the nerve center of the TR-3 that performs all mechanical functions, at the same time indicating what modes of operation have been initiated and accomplished. The overall operation of a tape player depends on the reliability of this control center. In the TR-3, each of the operating modes has its own semiconductor logic circuit and switching between them is performed by semiconduc-

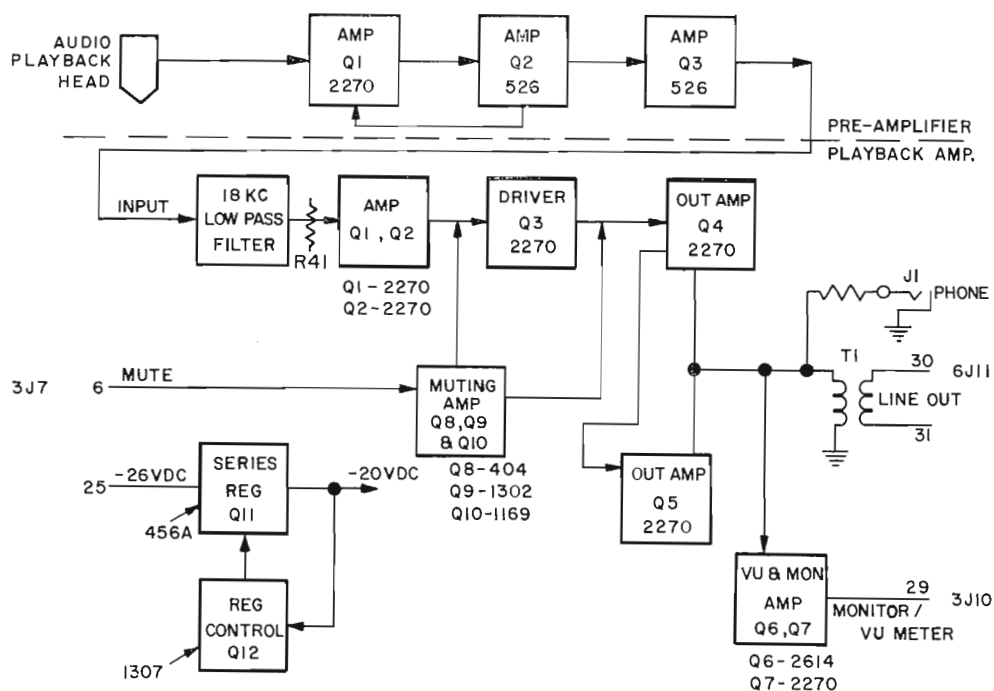

FIG. 10. Block diagram of TR-3 audio system.

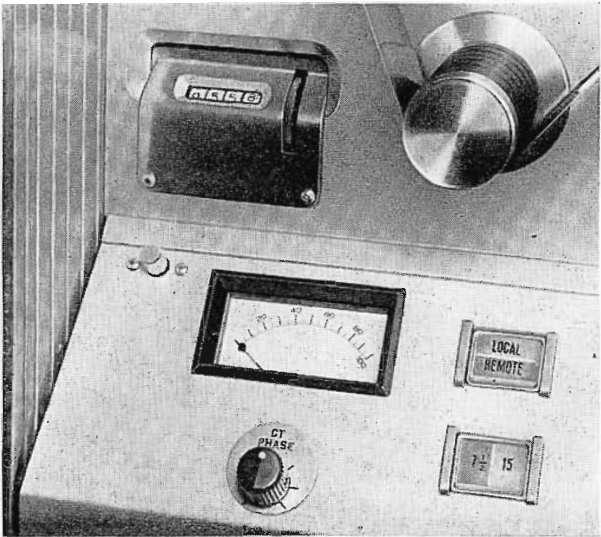

FIG. 11. TV tape timer (upper left).

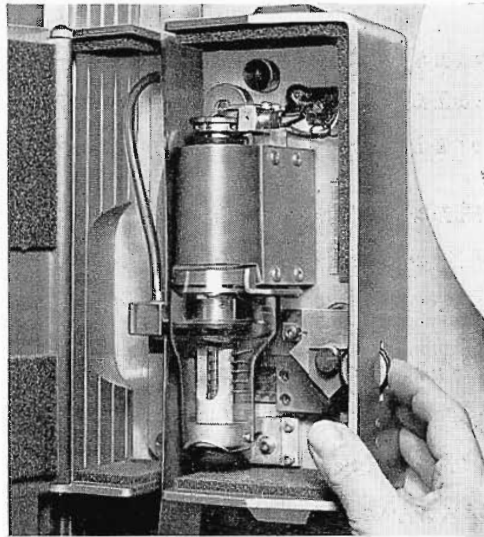

FIG. 12. Vacuum guide adjustment.

tors. Relays are used for switching AC voltages and heavy currents.

An operator initiates a desired function by pressing one of the buttons on the control panel—for example, the fast forward mode. This closes a switch allowing a momentary +70 volt signal to trigger the two-transistor, bi-stable PLAY control logic which latches in the “on” position and energizes the fast forward bus. At the same instant all other similar two-transistor bi-stable circuits receive an “unlatch” pulse. This turns off any other control circuit that might have been on before the operator pushed the fast forward button. Thus, the machine can be in only one mode at a time.

Another “inhibit” feature, preventing some of the common pitfalls occurring through operator mistakes, or tape faults, performs similar to the unlatch signal, except that its functions are specially selected for each mode. For example, to prevent possible damage by switching directly from a fast mode to a slower mode without going through stop, the fast mode circuit when actuated generates a signal that locks out the slower mode until the stop button is pressed. All of the functions that produce tape movement may be accomplished at a remote location for operator convenience.

Universal Standards

The design of the TR-3 permits use of world-wide TV standards. In addition to the domestic design for a 115 volt, 60 cycle power supply and 525-line scanning standards, there are two other models that operate on either 405/525/625 line switch-

able standards or 525/625/819 line switchable standards. These machines are normally supplied with a 230-volt, 50-cycle power supply, but a TR-3 with a 115-volt, 60 cycle supply is also available.

In the switchable standards models, standards are switched by means of a single rotary switch located on the vertical advance module. No additional equipment is necessary to make the switch between standards.

Monitor and Record Rack Accessory

Rack mounted monitor and record assemblies are available for those who wish

to convert their TR-3 player to a TR-4. The monitor rack assembly is a compact, self-contained monitoring unit which, through pre-wired harnessing, integrates itself with the various servo and video mechanisms in the TR-3. The rack contains an eight inch picture monitor, a waveform monitor, monitor switcher, and an audio monitoring system.

The picture monitor switcher is capable of selecting any one of the following: Demodulator out, video out, Mono ATC out, color out. In addition, tone wheel dots, representative of headwheel servo stability may be “supered” over any of the previous displays. The CRO Monitor can be switched to observe any of the following waveforms: Demodulator out, video out, FM switcher out, control track playback, capstan servo, reference pulse, and monochrome ATC error.

The monitor cabinet also contains space for addition of the record electronics, and internal mount air-bearing compressor kit.

The record accessory requires the monitor assembly as a pre-requisite, and comes with a pre-wired harness and module frame which bolt into the monitor assembly cabinet.

Included with the record accessory are the record modules, record connector frame and control panel.

The addition of these accessories convert the TR-3 into a complete TR-4. All the record accessories associated with the TR-4 may then be installed at the owner's

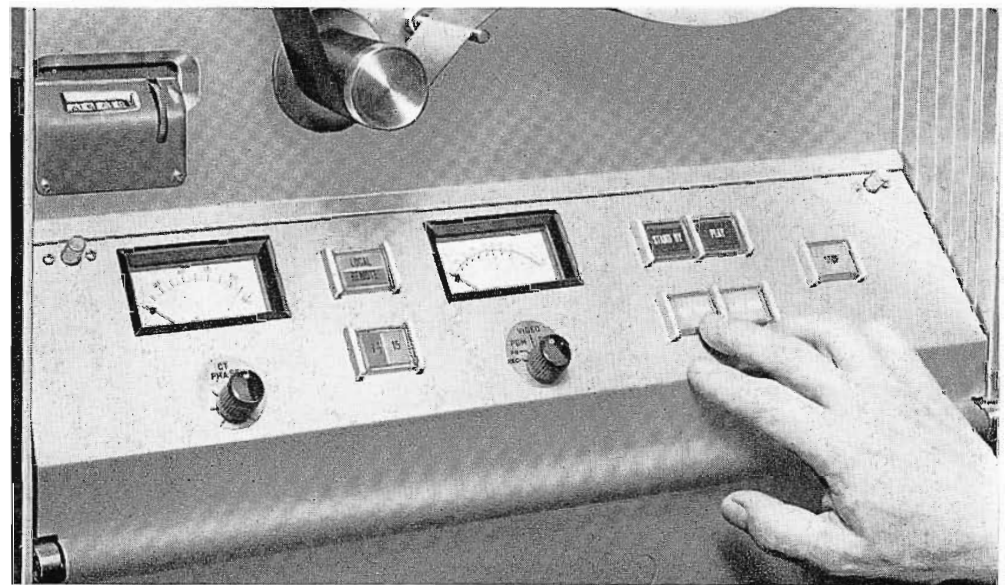

FIG. 13. Simplified control panel employs illuminated pushbuttons.



FIG. 14. Monitor/Record Rack Accessory.

option. This is an easy way to increase the versatility of the TR-3 in a two step process that is easy on the budget, while allowing playback of video tape at low initial cost.

Other Major Accessories

The TR-3 accommodates a full line of accessory equipments most of which are transistorized modules that can be plugged into the player with no need for external racks or mounts. Other accessories provide the convenience of remote operation such as might be desired for control of the remote player from the client's room. Following is a group of optional accessories:

Monochrome ATC—The automatic timing corrector removes all of the familiar picture blemishes such as residual picture jitter, quadrature errors, skewing and scalloping.

Color ATC—The color automatic timing corrector used with the mono ATC module provides for playback of color tapes in original full fidelity color.

Remote Panels—These provide for remote operation of the player by permitting remote control of both the mode functions and the electrical functions.

Air Bearing Conversion Kit

By substituting a pressurized air bearing assembly for the ball bearing type supplied, the motor shaft of the headwheel literally rides on a cushion of air. Metal friction is eliminated, near perfect rotation concentricity is achieved.

Conclusion

The TR-3 fills a long time need among broadcasters and educators, as well as advertising agencies, station reps, the military and others who use TV tape in closed circuit applications. It is a convenient and economical facility for playing video tapes at any time, especially when regular tape machines may be in use for editing or recording. It occupies considerably less space than other machines because it incorporates only the playback facility. Yet it is designed to accept a record assembly accessory to convert it to a record/playback unit. It is designed for the stringent requirements of color operation and requires only the accessory modules to be plugged in.

As the smallest tape playback unit available, the TR-3 effectively separates the record and playback functions, greatly increasing the flexibility and efficiency of any video tape operation, broadcast or closed circuit.

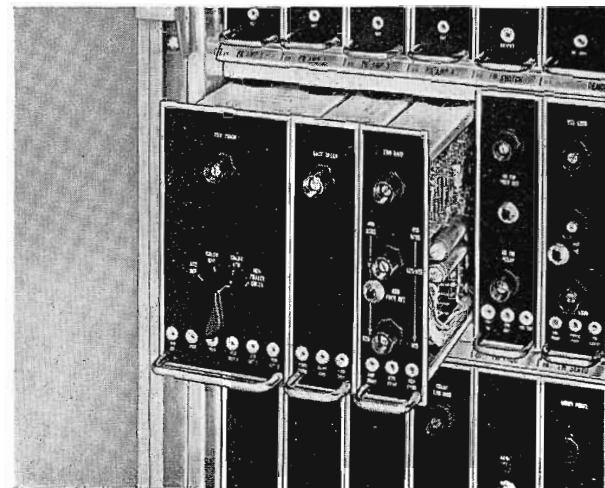

FIG. 16. Monochrome ATC accessory.

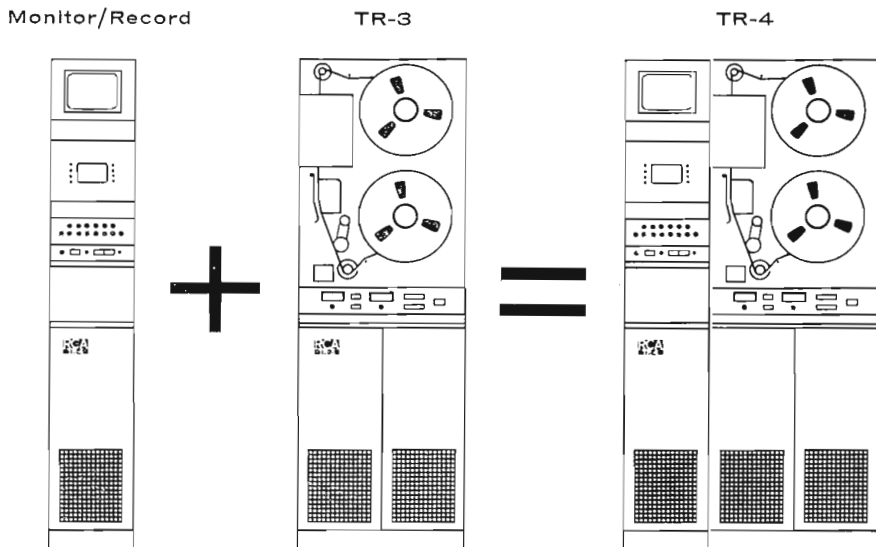

FIG. 15. Adding the Monitor/Record accessory converts to a TR-4.

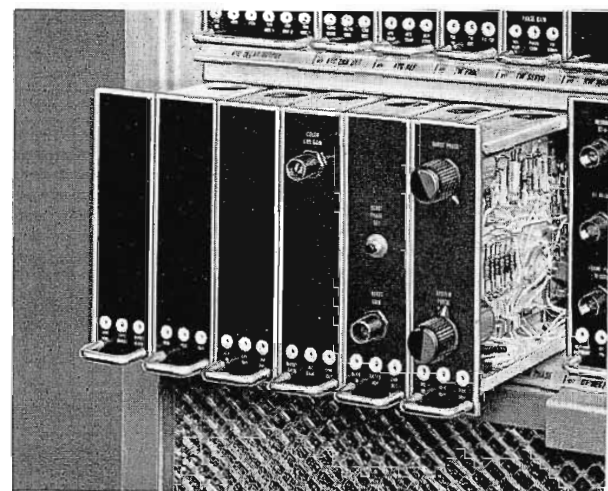

FIG. 17. Color ATC accessory.



FIRST FULLY INTEGRATED TV TAPE RECORDING SYSTEM

for high-



band color

Superb Multiple Generation Color Tapes

The TR-70 makes superb copies of color tapes that look for all the world like the original. Improvements in signal-to-noise, bandwidth, and "K" factor account for the superiority in picture performance. The TR-70 maintains this uniformly high quality on a day-to-day basis.

Color Tested . . . Color Ready

The TR-70 is built and tested at the factory as a complete color system. Its system features include: ATC, Air-bearing Headwheel, Color ATC and Switchable Standards. This means that the user may produce color tapes and go on-air immediately.

High Band at Touch of a Button

There is instant selection of three recording standards—low band monochrome, low band color, or high band monochrome/color.

The TR-70 is RCA's newest and the first fully integrated high band color tape system. This "state of the art" system means best possible design and performance. Discover for yourself why the TR-70 color system is superior to any TV Tape Recorder built to date.

Call your RCA Representative. Or write RCA Broadcast and Television Equipment, Building 15-5, Camden, New Jersey.



TR-70 makes multiple-generation color tapes look like originals.



TR-70 has "instant selection" of high band or low band, color or monochrome.

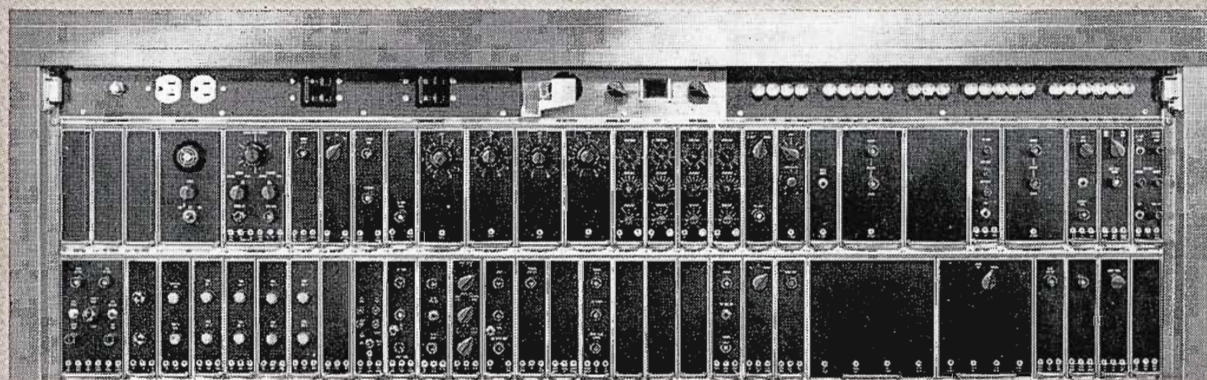

TR-70 comes with color modules installed, wired and "system tested" at the factory.



The Most Trusted Name in Television

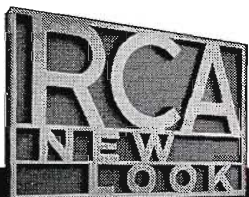

for UHF BROADCASTERS

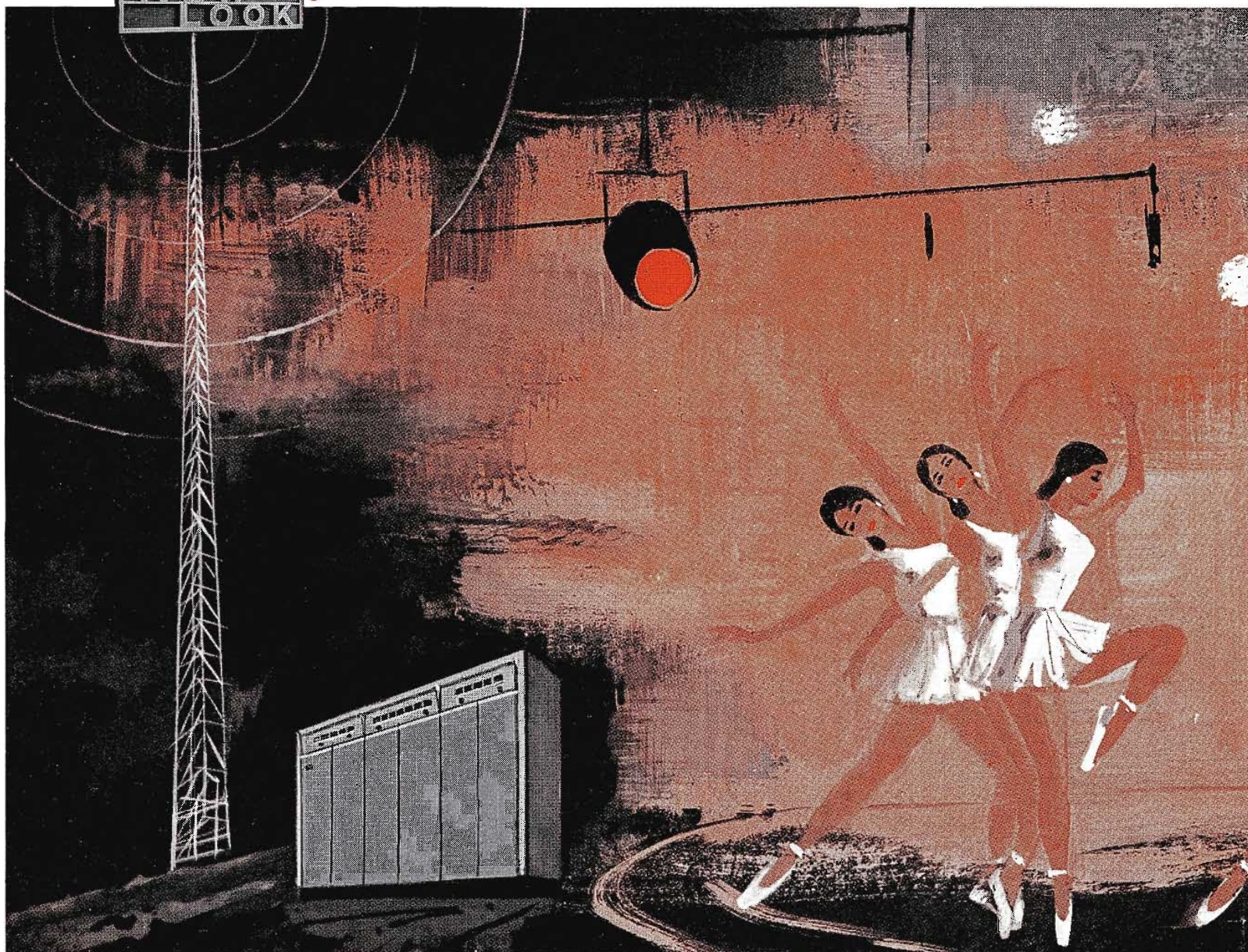

...puts a new dimension

Space age electronics gave birth to what is known as the RCA "New Look." From its all-new styling to its self-adjusting transistor circuits and modular design the "New Look" adds a new dimension to equipment planning. This equipment offers *new* compactness of size, *new* reliability and stability, *new* simplicity of operation and maintenance.

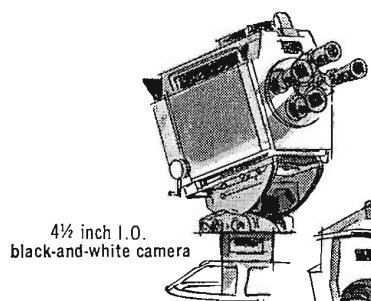

4 1/2 inch I.O. black-and-white camera

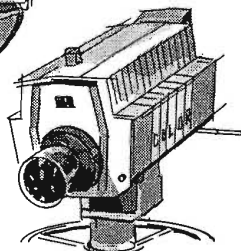

Revolutionary "black tube" color camera

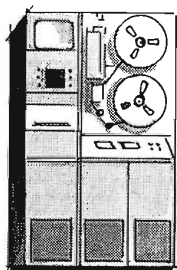

Compact TV Tape Recorder for color

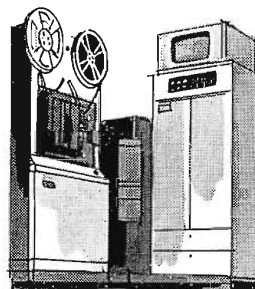

Unique "big tube" color film system

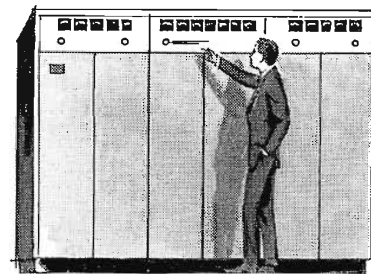

"New Look" UHF television transmitter



in UHF planning!

For example, the new 30 kw UHF transmitter, Type TTU-30 — with radically new klystrons of vapor-cooled type, saves space and costs, radiates as much as 1¼ million watts. It's just one of many "New Look" equipments that are years ahead in design and performance.

When you come to RCA for your UHF equipment, you are coming face to face with an old hand in television station engineering . . . pioneer in UHF since the very beginning. There's a complete package . . . from cameras, film and tape equipment . . . to transmitters and antennas, as shown below.



Pylon antennas

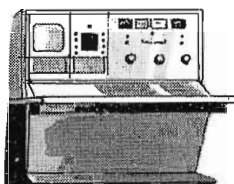

"New Look" control equipment



The Most Trusted Name in Television

RCA SERVICE

keeps all your
AM, FM, TV
equipment
in top
condition!

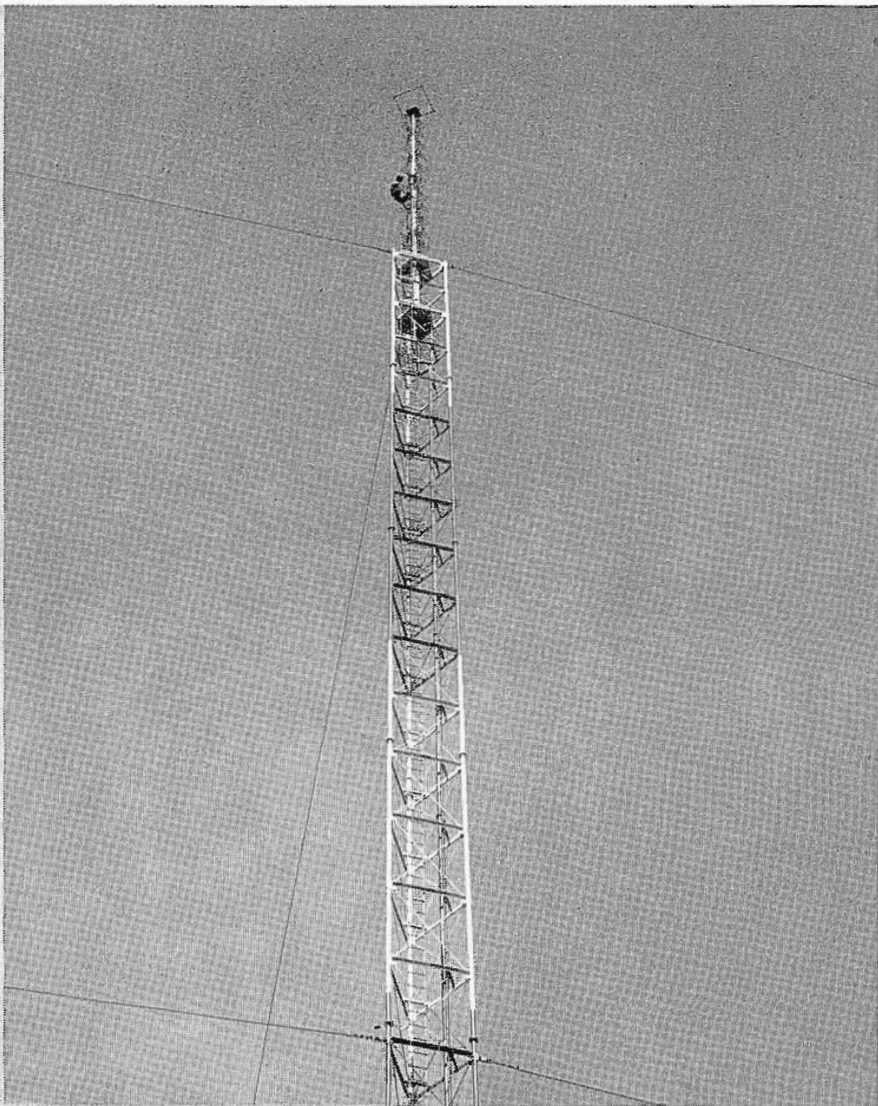

Antenna System Measurements

TAKE ADVANTAGE OF THE FOLLOWING SERVICES OFFERED BY RCA:

- Video Tape Recorder Service • TV Camera Overhaul • TV Transmitter Overhaul
- Installation Supervision • Microphone and Pick-Up Repairs • Transmitter Performance Measurements • Antenna Inspection Measurements • Console Repairs • Microwave Service
- TV Projector Service • Custom Fabrication • Teletypewriter Maintenance

Your audience demands a superior signal which requires top performance from all your station equipment. RCA Broadcast Service is planned to assure you of meeting this objective. More than 30 years in the broadcast industry have provided a background of solid service experience. This is the type of protection broadcasters have relied on for years, the kind of protection you can count on . . . contract or per-call . . .

from the experts in the service business, RCA Service Company. To guard performance of all your equipment . . . simply telephone one of the following field offices: Atlanta (phone 355-6110), Chicago (WE 9-6117), Phila. (HO 7-3300), Hollywood (OL 4-0380). Or contact Technical Products Service, RCA Service Company, A Division of Radio Corporation of America, Bldg. 203-1, Camden, N.J. 08101.



The Most Trusted Name in Electronics

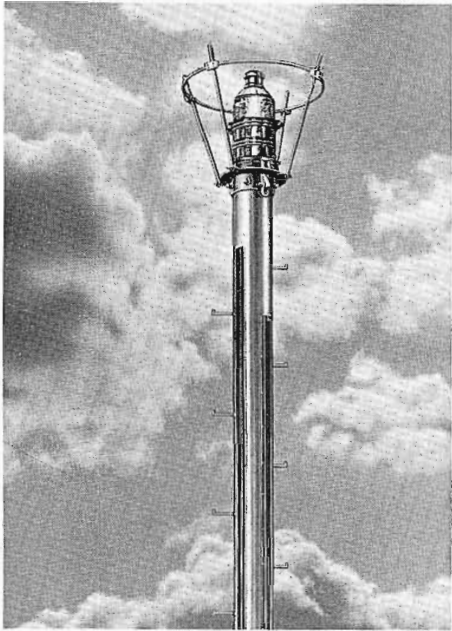

RCA VHF
(Traveling Wave)
and UHF Pylon Antennas

Just a "little bit of paint"
is enough to maintain ...

RCA high-performance antennas!

SUPERIOR IN LOW MAINTENANCE

Other than an occasional coat of paint to meet FAA rules, practically no maintenance is required by "Pylon" Antennas. (Actually, a weatherproof, galvanized coating provides sufficient protection.)

SUPERIOR IN PERFORMANCE

"Pylon" antennas are engineered to provide excellent pattern circularity. Coverage is essentially the same in all directions (subject, of course, to terrain conditions). Pictures are sharp and snappy, as a result of excellent impedance match across channel.

SUPERIOR IN RELIABILITY

"Pylon" antennas combine radiating surfaces and supporting structure into a simple "pole"—in which all electrical circuitry is contained. Since it has no appendages to catch the wind, tower load is reduced—and, it's impervious to lightning! Rugged design makes this antenna the ultimate in stability.

SUPERIOR IN STATION PREFERENCE

Many stations have been influenced by the remarkable performance record of these antennas—and some have switched. Several have even taken ads to tell of their success with the "Traveling Wave" (see right).



RCA Testing Facilities are the finest and most complete in the nation.

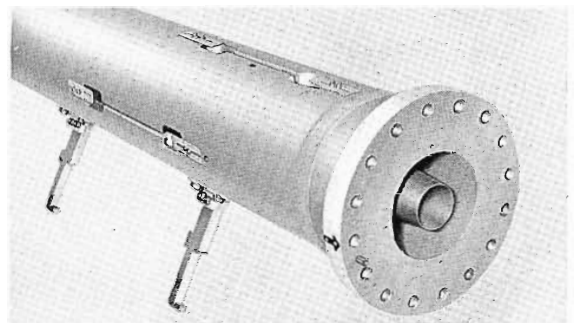

View showing simple design of "Pylon" Antennas

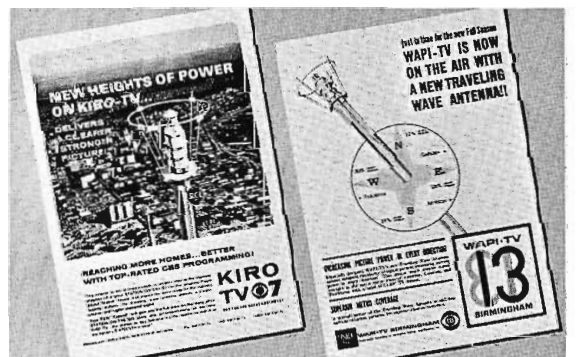

Two of the stations that have "switched" to "TW" Antenna.

For further information, write RCA Broadcast and Television equipment, Building 15-5, Camden, N. J. Or call your RCA Broadcast Representative.



The Most Trusted Name in Television



"PYLON" ANTENNA...AND A LITTLE PAINT!

